

**AXIS**  
OFF-ROAD

# 450cc UTILITY

## OWNERS MANUAL



PUBLISHED BY CHONGQING HUANSONG INDUSTRIES (GROUP) CO., LTD AND HISUN MOTORS CORP., USA. CHONGQING HUANSONG INDUSTRIES (GROUP) CO., LTD AND HISUN MOTORS CORP., USA HOLD THE COPY RIGHT. NO PUBLISHING OR REPOINTING WITHOUT PERMISSION.

# **Introduction 450cc Utility**

## **INTRODUCTION**

Congratulations on your purchase of the 450cc Utility. This Owner's / Operator's manual will provide you information regarding safe operation, operational instructions, maintenance and care. Fully understanding this manual and following all of the instructions herein will provide the knowledge needed to have safe and enjoyable UTV operation.

**For questions regarding this UTV, please call (972) 446-0760.**

### **IMPORTANT SAFETY MESSAGES**

- **READ THIS MANUAL CAREFULLY AND COMPLETELY BEFORE OPERATING YOUR UTV. MAKE SURE YOU UNDERSTAND ALL INSTRUCTIONS.**
- **PAY CLOSE ATTENTION TO THE WARNING AND CAUTION LABELS ON THE UTV.**
- **NEVER OPERATE THE UTV WITHOUT PROPER TRAINING OR INSTRUCTION.**
- **THIS UTV SHOULD NOT BE RIDDEN BY ANYONE UNDER 16 YEARS OF AGE.**

# Introduction 450cc Utility

## IMPORTANT MANUAL INFORMATION

**FAILURE TO FOLLOW THE WARNINGS CONTAINED IN THIS MANUAL CAN RESULT IN SERIOUS INJURY OR DEATH.** Particularly important information is distinguished in this manual by the following notations:



The Safety Alert Symbol means **ATTENTION!**  
**YOUR SAFETY IS INVOLVED!**



Failure to follow **WARNING** instructions could result in severe injury or death to the machine operator, bystander or a person inspecting or repairing the machine.



A **CAUTION** indicates special precautions that must be taken to avoid damage to the machine.

**NOTE: A NOTE** provides key information to make procedures easier to understand.

# Introduction 450cc Utility

## IMPORTANT NOTICE

This UTV is designed and manufactured for **OFF - ROAD** use only. It is illegal and unsafe to operate this UTV on any public street, road or highway.

This UTV complies with all applicable **OFF - ROAD** noise level and spark arrestor laws and regulations in effect at the time of manufacture.

Please check your local riding laws and regulations before operating this UTV.

When the temperature is below -4°F (-20°C), park the UTV in a place where the temperature is higher than -4°F (-20°C). Start the UTV after the UTV has warmed up. Please see page 7-3 on the warming up process.

Follow the proper parking procedures when the temperature is higher than 100°F (38°C): turn off the engine; make sure the radiator fan is on for 3 minutes before turning off the power switch.

Starting the UTV for the first time will take longer because the fuel will need reach the fuel injectors. To start the UTV the first time, hold the ignition key on at 5-second intervals. Allow the starter to rest 15 seconds between each start attempt.



# Introduction 450cc Utility

## UNIVERSAL SYMBOLS

As a guide to the operation of your vehicle, various universal symbols have been utilized on the instruments and controls. The symbols are shown below with an indication of their meaning.



Safety Alert Symbol



Diesel Fuel



Engine coolant-Temperature



Parking Brake



Battery Charging Condition



Engine Oil-Pressure



Turn Signal/Hazard



Differential Lock



Position Lights



Lift Cylinder-Retract



Lift Cylinder-Extend

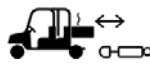

Lift Cylinder-Float



Hazard Warning Lights



High Beam



Horn



EPS System Error



2WD/ 4WD

# Introduction 450cc Utility

## Table of Contents

<u>Subject</u>	<u>Page</u>	<u>Subject</u>	<u>Page</u>
<b>Introduction</b>	<b>1-1</b>	Seat belt	8-1
Important manual information	1-2	Head light switch	8-2
Important notice	1-3	Hazard light switch	8-2
Universal symbols	1-4	Turn signal light switch	8-2
Location of parts	1-7	Brake pedal	8-3
Illustrated contents	1-8	Range gear shift lever	8-3
<b>Safe operation</b>	<b>2-1</b>	4WD lever	8-4
Safety instructions	2-1	Accelerator pedal	8-5
Operation	2-2	Stopping	8-5
Children safety instructions	2-2	Coolant temperature gauge	8-5
Driving on a slope	2-3	<b>Winch operations</b>	<b>9-1</b>
Driving in harsh conditions	2-3	Transporting vehicle	9-1
Driving at high speed	2-3	Service intervals	9-2
Instructions for cargo bed	2-4	<b>Periodic service</b>	<b>10-1</b>
Parking	2-4	How to open the front hood and seat	10-1
Transporting vehicle	2-4	Front hood cover	10-1
Maintenance	2-4	Operator's sea	10-1
<b>Warning and caution labels</b>	<b>3-1</b>	How to raise the cargo bed	10-1
<b>Servicing of vehicle</b>	<b>4-1</b>	Raising and Lowering the Cargo Bed	10-1
<b>Specifications table</b>	<b>5-1</b>	Jack-up point	10-2
Vehicle limitations	5-3	Front end	10-2
<b>Pre-operation</b>	<b>6-1</b>	Rear end	10-2
<b>Operating the engine</b>	<b>7-1</b>	Daily check	10-2
Starting the engine	7-1	Walk around inspection	10-3
Cold starting	7-2	Checking and Refueling	10-3
Stopping the engine	7-2	Checking coolant level	10-3
Warming up	7-2	Cleaning radiator screen	10-4
Warming Up Transmission	7-2	Checking brake fluid level	10-4
<b>Operating the vehicle</b>	<b>8-1</b>	Checking brake pedal	10-5
Operating new vehicle	8-1	Checking parking brake	10-5
Do not operate the vehicle at full speed for the first 50 hours	8-1	Checking gauges and indicator lights	10-6
Changing lubricating oil for new vehicles	8-1	Checking head light turn signal light etc	10-6
Starting	8-1	Checking seat belt and ROPS	10-6
		Checking joint boot	10-6

## Introduction 450cc Utility

Checking tire inflation pressure	10-6	Replacing brake master cylinder (inner parts)	10-18
Every 50 hours	10-6		
Greasing	10-6	Replacing front brake seal	10-18
Checking engine start system	10-7	Replacing rear brake cylinder seal	10-18
Checking wheel bolt torque	10-7	Replacing intake air line	10-18
Cleaning air cleaner primary element	10-8	Every 4 years	10-18
Checking battery condition	10-9	Replacing brake hose	10-18
Adjusting toe-in	10-10	Replacing slow-blow fuses	10-18
Cleaning muffler	10-11	Storage	10-19
Every 200 hour	10-11	Vehicle storage	10-19
Changing engine oil	10-11	Removing the vehicle from storage	10-20
Replacing engine oil filter	10-12	<b>Troubleshooting</b>	<b>11-1</b>
Replacing transmission oil	10-12	Engine troubleshooting	11-1
Checking brake pedal	10-13	Diagnostic trouble code table	11-2
Checking brake hose and pipe	10-13	Battery troubleshooting	11-3
Checking brake light switch	10-13	Machine troubleshooting	11-4
Checking radiator hose and clamp	10-13	<b>Accessories</b>	<b>12-1</b>
Checking intake air tube	10-14	<b>Emissions warranty</b>	<b>13-1</b>
Every 300 hours	10-14		
Checking tire	10-14		
Every 400 hours	10-15		
Changing transmission fluid	10-15		
Changing front and rear axle case oil	10-15		
Every 500 hours	10-15		
Replacing fuel filter	10-15		
Every 1500 hours	10-16		
Checking injection and fuel pump	10-16		
Every 1 year	10-16		
Every 2 years	10-16		
Flushing Cooling system and changing coolant	10-16		
Anti-freeze	10-17		
Replacing radiator hose (water pipes)	10-18		
Replacing fuel hose	10-18		

# Introduction 450cc Utility

## LOCATION OF PARTS

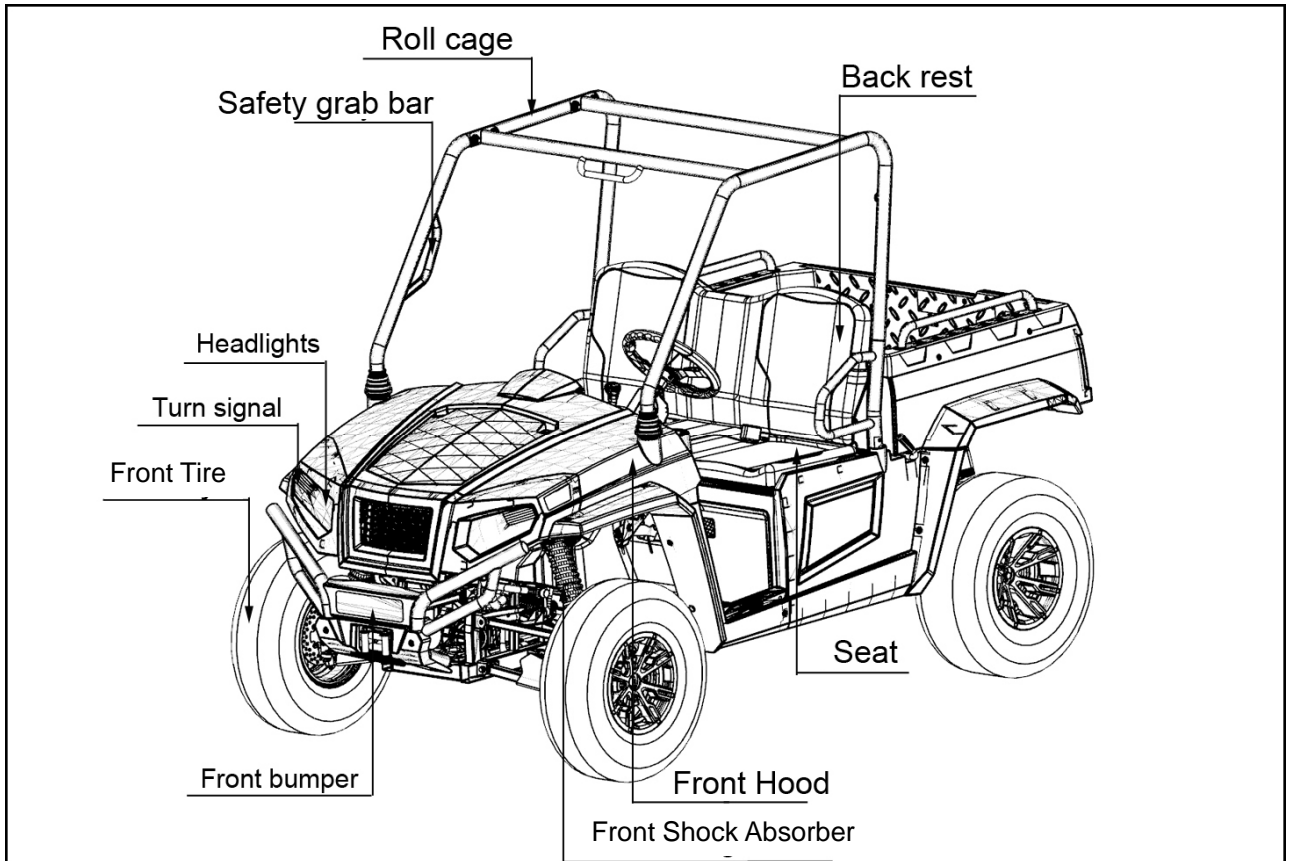



# Introduction 450cc Utility

## ILLUSTRATED CONTENTS

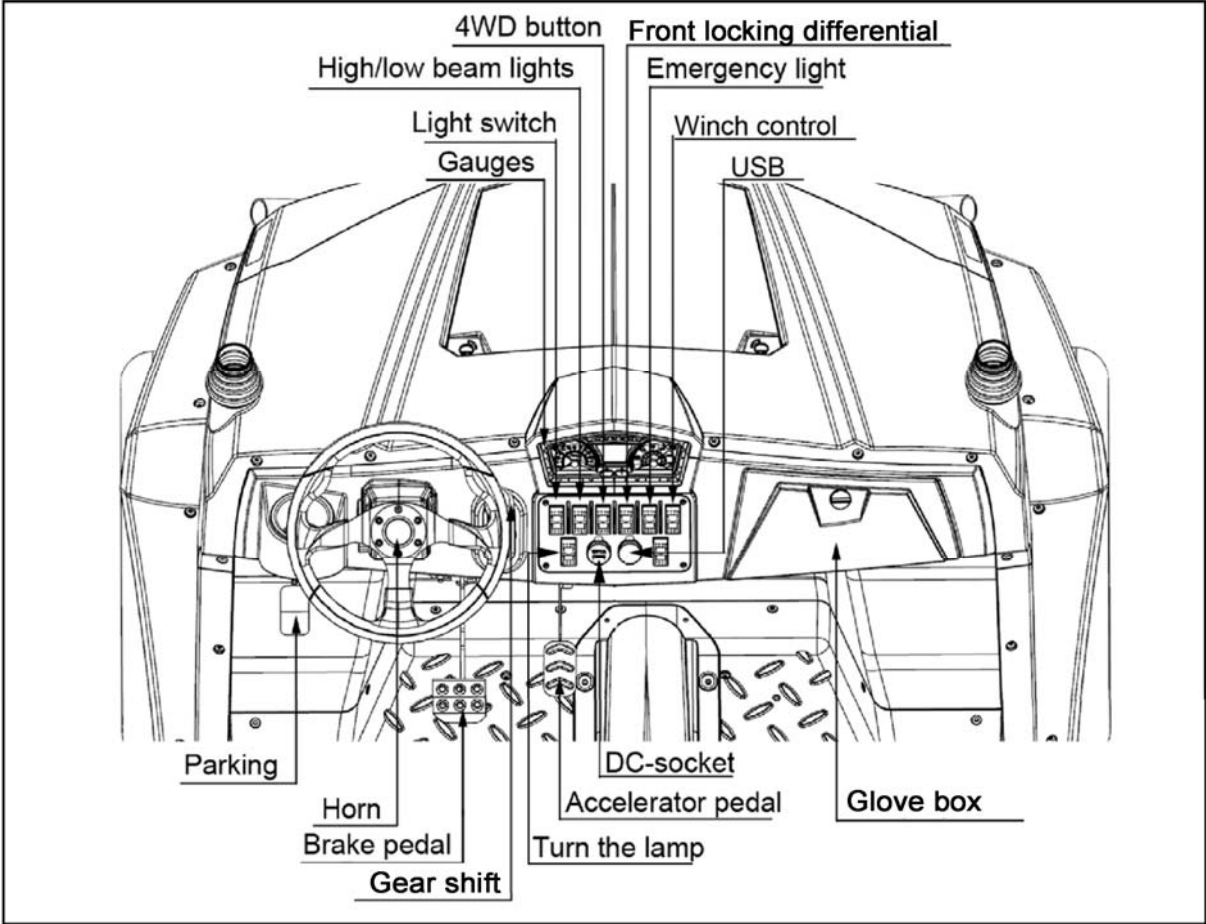

## Introduction 450cc Utility

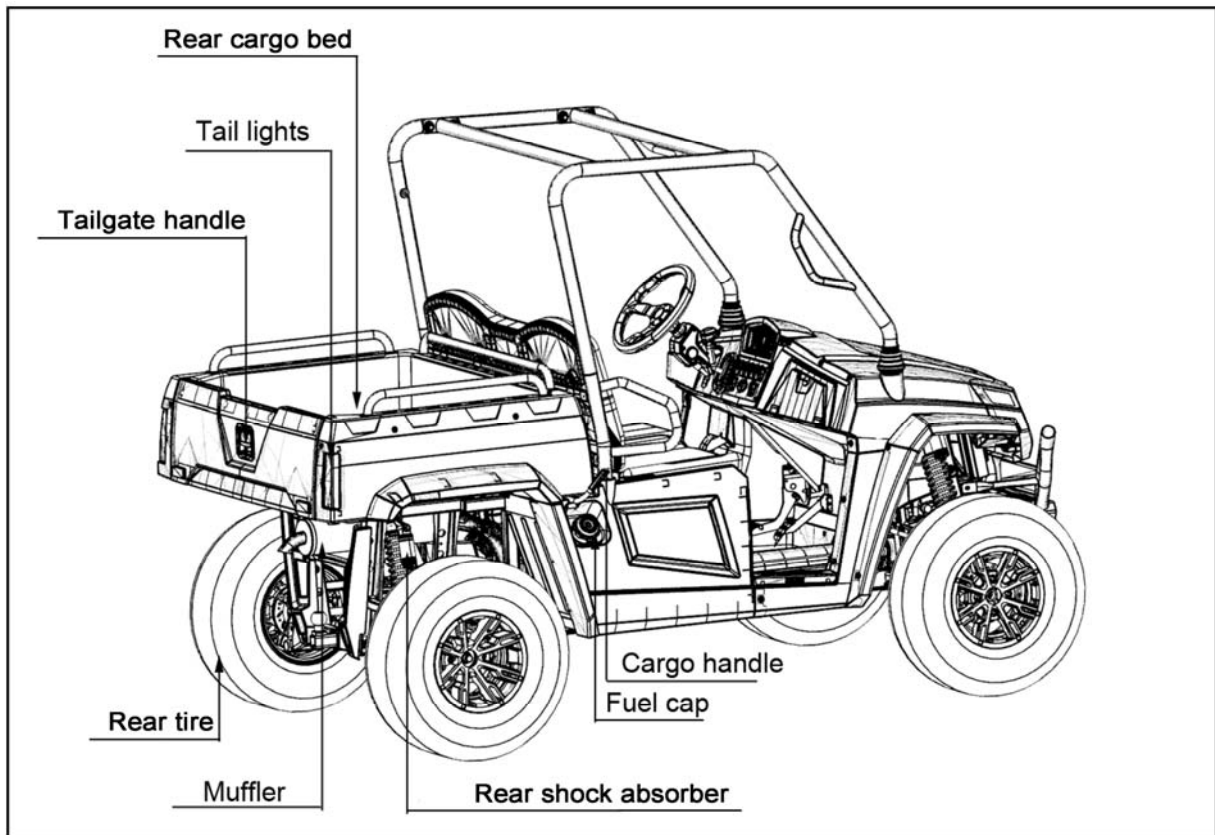

# Safe Operation

All operators, including experienced UTV drivers or passengers, should carefully read and fully understand this Users Manual, and operate strictly as the manual states in order to achieve best performance and avoid accidents. Others who will use your UTV should be trained how to operate the UTV and be required to read this manual before operation.

## 1. Safety Instructions:

1. Understand this UTV by reading this manual and understanding all the components of the vehicle. Only start and operate the vehicle after finishing reading this manual.
2. Pay close attention to the warning and caution labels on the UTV.
3. Understand completely and learn to use the safety devices (cab frame structure, seat belts), and never change original safety devices. If safety devices are damaged, consult your local dealer for replacement. Always use seat belts.

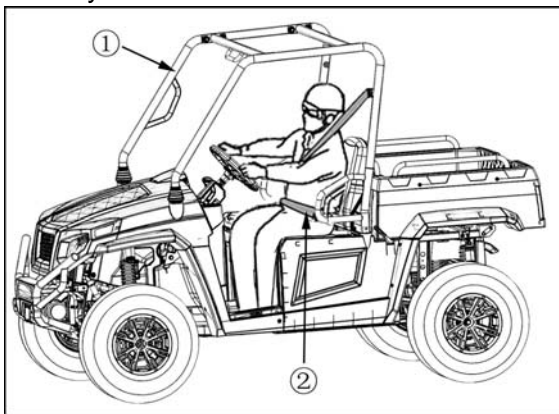

- ① Cab frame structure
- ② Seat belts

4. Do not wear loose articles of clothing during operation, as these can be drawn into

moving parts on the vehicle and could cause a severe injury to occur.

You should wear protective devices, such as helmet, boots, eye protection, earmuff, gloves and etc.

5. Only a qualified driver should operate this UTV. Never operate after drinking, using drugs or controlled products, or while fatigued.
6. Always perform the pre-operation checks as following:
  - 1) Check seat belt for worn or damaged, if necessary, replace it.
  - 2) Check brakes, throttle, brake pedal and other mechanical parts for proper operation. If you discover any irregularities, replace related parts as necessary. Periodically check the fittings and fasteners.
  - 3) Check engine oil level and engine coolant level.
  - 4) Check that the UTV is equipped to handle the surroundings.
  - 5) Check and keep vehicle clean. Sludge, grease and debris can cause a fire and severe injury.
7. Passenger quantity and loading:
  - 1) Only the driver and one passenger inside cab. It is suggested that children under age of 5 not be allowed as a passenger.
  - 2) Do not exceed vehicles Total Load Capacity rating of 880 lbs. (399 kg). Reduce loading weight according to road condition. Never exceed the weight limits for operation.

# Safe Operation

8. Never allow unauthorized persons to repair this UTV. This may affect vehicle performance and cause injury.
9. This UTV is designed and manufactured for off-road use only, so never drive on paved roadways.

## 2. Operation

1. Start the engine only in an open ventilated area. Carbon monoxide is colorless, odorless and is emitted from the engine and can cause death in areas with poor ventilation.
2. Never start the vehicle or operate the gear selector unless seated in the driver's seat.
3. Never start engine before placing the gear shift lever in the "N" position.
4. The driver and passenger shall always wear their seat belt while the vehicle is being operated.
5. Operators of the UTV should not wear earphones.
6. Use trailer hitch to trail cargo, otherwise, serious injury or death will happen.

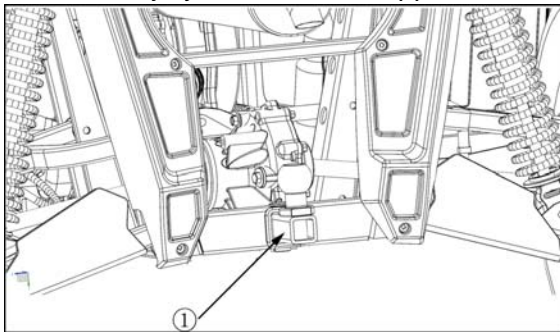

① Receiver Hitch

7. Do not accelerate quickly when starting the engine, especially driving on rough terrain as this can cause injury or death. Press the accelerator pedal slowly.

8. Drive at slow speed before braking.  
When press the differential unlocked (DIFF.LOCK is off) when pressing, the front/rear wheels can turn at different speed. Otherwise, the vehicle may turnover.
9. Never drive over terrain such as a ditch, a hole, dams, excessive mud, or the vehicle can get stuck because of the vehicles weight.
10. Always pay close attention to your surroundings, and check for streets, trail intersections or other obstacles.
11. Always use signals in advance of turns.
12. Do not allow entrance or exit of the vehicle while it is moving.
13. Clean dash board and Keep the floorboard free of debris that can obstruct the ability to use the brake pedal.
14. Position your hands on the steering wheel. Always keep your hands and feet inside passenger area of the vehicle. Never try to stand while operating the vehicle.
15. Do not tow passengers, or attempt to jump the vehicle.
16. The buzzer will keep buzzing if the park is on when driving.

## 3. Children safety instructions

Always watch children when they are around the vehicle. Children like to imitate adults and this could lead to an accident.

Do not leave children alone around the vehicle. Keep children from the operating area of the vehicle.

Turn off the engine and remove the key when children are in the operating area.

Never carry children in the cargo bed. This is



## Safe Operation

very dangerous to children. Children under age of 5 are not allowed to take this vehicle.

Never allow children to climb on the vehicle even if they are under adult supervision, or climbing on vehicle.

Always check for people or obstacles behind the vehicle before shifting the vehicle into reverse.

Avoid a collision with an obstacle or person.

Park the vehicle on level ground. If parking on a slope, you should use parking brake, remove the key, and vehicle will stay stationary after letting off brakes.

### 4. Driving on a slope

Be cautious when riding on a slope, as this could result in loss of control or overturn, leading to severe injury.

1. Drive up and down on a slope at a low-speed.
2. Reduce weight when ride on a slope or rough terrain.
3. Avoid the sudden application of the brakes when you go uphill or downhill. Be more careful when vehicle turns on a slope.
4. If you start to lose momentum or need to park when climbing, use the parking brake to come to a stop. Release the brake and begin to coast down the hill.
5. If you do not believe you can operate the UTV safely in reverse do not attempt to ascend the slope any further.
6. Riding in mud, a ditch, and on slopes will increase the risk of an overturn. Be more cautious when operating. Drive gradually and slowly when climbing. Avoid sudden changes

of vehicle speed or direction.

### 5. Driving in harsh conditions

1. Vehicle can be operated during the day or under good light conditions.
2. Operate the vehicle level ground as much as possible.
3. Both operator and passengers should wear helmet and protective equipment.
4. Driver should slow down according to road conditions, terrain, visibility conditions.
5. Be cautious when driving over a ditch, stone road or hidden obstacles.
6. Avoid operating in any unknown depth of water. (water depth should not exceed axle height)

### 6. Driving at high speed

1. Check for front/rear wheels conditions. Pay attention to the difference of braking performances between two and four-wheel drive.
2. Slow down when turning. Turning at high speed may result in overturn or even death.
3. Turn on your headlights at high speeds.
4. Drive only when the vehicle speed can be controlled.
5. Do not use DIFF.LOCK when driving at high speed. Otherwise, this may cause vehicle loss of control.
6. When driving at high speed, suddenly turning the steering wheel will reduce vehicle stability. Never sharply turn the steering wheel at high speeds.

# Safe Operation

## 7. Instructions for cargo bed

1. Never carry a passenger in the cargo area.
2. Evenly distribute the cargo to maintain proper stability. Avoid overloading the carrier. Cargo should be securely attached.
3. Reduce loaded weight when driving on poor road conditions or steep inclines.
4. Do not put your hands and you body under the cargo bed when it is raised. Once lowered, lock the cargo bed in place before operating the vehicle. Never driving before securing and locking the cargo bed.

## 8. Parking

1. Set the gear shift to the “N” position and To release the parking brake, depress the brake pedal.

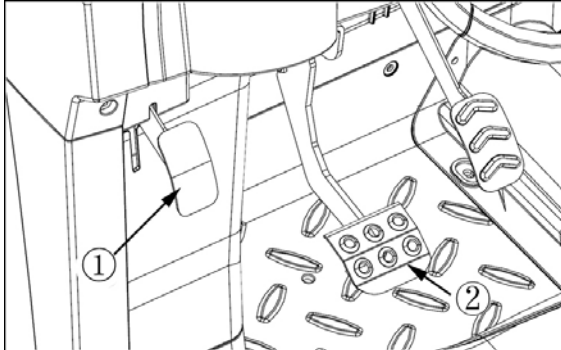

① Parking brake.

② Brake pedal

2. Avoid stopping the vehicle on a slope. If stopping on a slope make sure the vehicle is stationary before exiting.

## 9. Transporting vehicle

1. Avoid dragging the vehicle behind another vehicle. Use a trailer or truck to transport the vehicle.

2. When loading or unloading, pay attention to your surroundings and others in the area.

## 10. Maintenance

Stop the vehicle and park it on level ground. Pull the parking brake and remove all cargo. Then place shift lever on “N” position, stop the engine and remove the key.

1. When working next to the engine, exhaust or radiator, work only after it has cooled down.
2. Wait for the engine to stop running and cool down before checking the coolant level. Otherwise, you could be burned by hot fluid or steam blown out.
3. No smoking when adding electrolyte or refueling. Fuel tank and battery should be kept away from sparks. Battery produces hydrogen and oxygen during charging and this could accelerate the risk of explosion.
4. Read and follow the instructions before replacing the battery.
5. During maintenance, first aid kits and fire extinguishers should be placed at your fingertips.
6. During maintenance, you should disconnect the battery cables.

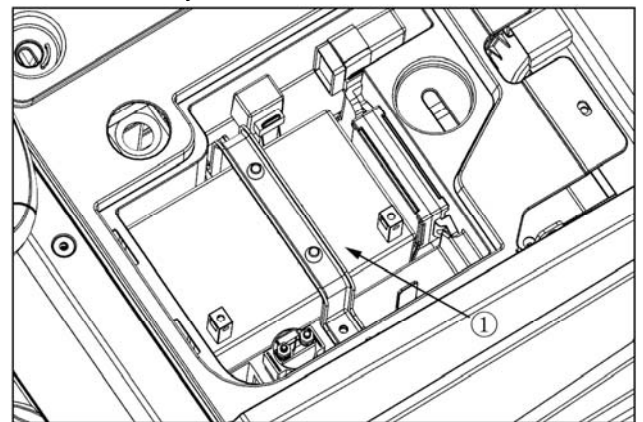

① Battery

## Safe Operation

7. Do not open radiator cap before coolant has cooled down. When the coolant is cold, open slowly to ensure no pressure is on the system, and then open cap. Check for the coolant level in the coolant reservoir. If necessary, add coolant.
8. Tires should be mounted on rims with special equipment by professionals.
9. Keeping specified tire pressure can help to ensure driving safety.
10. Elevate the vehicle and place a suitable stand under the frame when removing the wheels, Be sure to tighten the wheel nuts to specified torque.

# Warning Labels

## Warning and caution labels

(1)



(2)



(3)

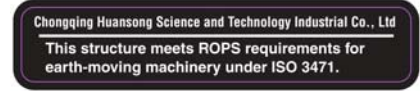

(4)



(5)

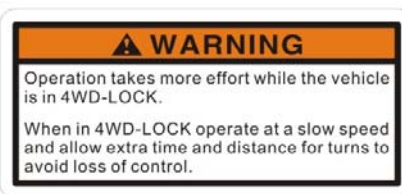

(6)

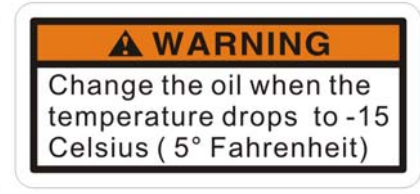

(7)



(8)



(9)





# Warning Labels

(10)

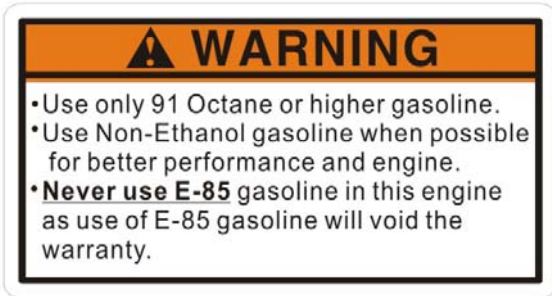

(11)

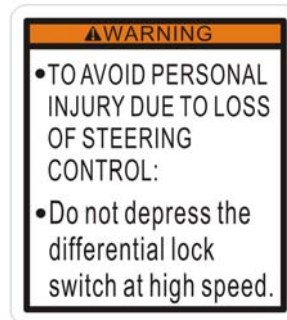

(12)



(13)

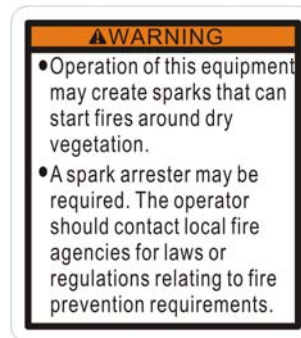

(14)

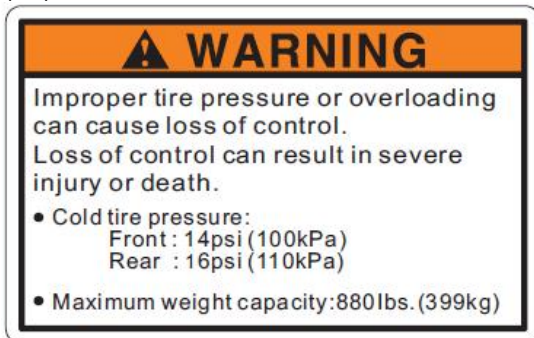

(15)



(16)

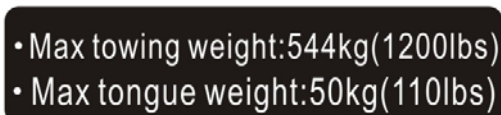

## Vehicle Identification Number

# SERVICING OF VEHICLE

Your dealer is interested in your new vehicle and has the desire to help you get the most value from it. After reading this manual thoroughly, you will find you can do some of the regular maintenance by yourself.

However, when in need of parts or major service, be sure to see your dealer.

For service, contact the dealership from which you purchased your vehicle or your local dealer.

When in need of parts, be prepared to give your dealer both the vehicle and engine serial numbers.

Locate the serial numbers now and record them in the space provided.

	Type	Serial No.
Vehicle		
Engine		
Product Identification Number		
Date of Purchase		
Name of Dealer		

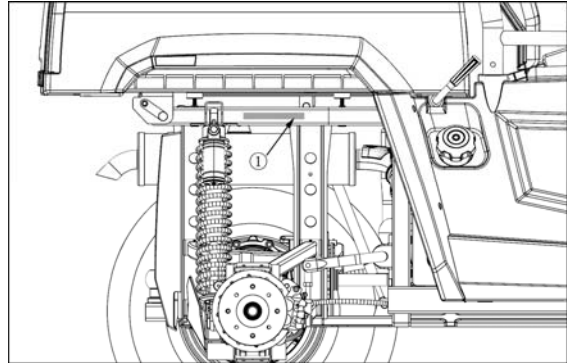

① Vehicle serial number.

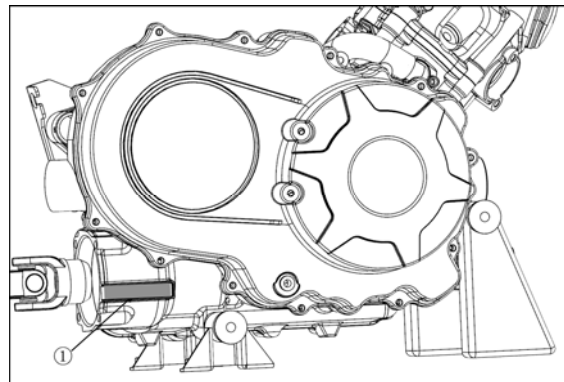

① Engine serial number

# Specifications

## SPECIFICATION TABLE

Engine	Make		Specification	
	Type		1-cylinder, 4-cycle, gasoline, SOHC, liquid cooled	
	Displacement	CC	454CC	
	Horsepower	Kw(HP)	17.2kw (23.1)	
	Rated revolution	rpm	5500	
	Low idling revolution	rpm	1500 ±150	
Fuel Capacity		L(U.S.gas)	28 (7.4)	
Transmission			CVT	
Wheels, Drive system			4, Rear 2WD or 4WD	
Differential lock			Electric control: switch	
Gear selection			F-N-R for HS400UTV-4 H-L range forward, N, R for HS450UTV	
Brakes	Front/Rear		Hydraulic disk brake	
	Parking brake		Mechanical brake	
Steering			Mechanical	
Suspension	Front		Independent, Dual A-arm type	
	Rear		Independent, Dual A-arm type	
Dimensions	Length		mm(in.) 2720 (107.09)	
	Wide		mm (in.) 1550 (61.02)	
	Height		mm (in.) 1885 (74.21)	
	Front tread centers		mm (in.) 1350 (53.15)	
	Rear tread centers		mm (in.) 1300 (46.5)	
	Wheelbase		mm (in.) 1850 (51.18)	
	Ground Clearance	front axle	mm (in.)	310 (12.2)
		rear axle		310 (12.2)
Turning diameter		m (ft)	6.84 (22.44)	
Max. rolling weight (Towing Capacity)		kg (lbs.)	544 (1200)	
Payload capacity		kg (lbs.)	159 (350)	
Weight		kg (lbs.)	620 (1367)	

## Specifications

Model		Specification	
Cargo bed	Width	mm (in.)	1305 (51.38)
	Length	mm (in.)	775 (30.51)
	Depth	mm (in.)	285 (11.22)
	Volume	m <sup>3</sup> (cu.ft.)	0.23 (8.11)
	Bed height (unloaded)	mm (in.)	927 (36.50)
	Cargo bed capacity (1 row/2 row)	kg (lbs.)	159 (350)
Sound level, operator ear		db (A)	85
Tire	Front	25x8-12, 26x9-12 6PR	
	Rear	25x10-12, 26x10-12 6PR	
Body color		Red, Black, White, Blue, Yellow, Orange, Camo	

**NOTE:**

- The values in “Ground clearance” and “Weight” are those of the machine equipped with the tires in the table above.
- The company reserves the right to change the specifications without notice.

### TRAVELING SPEEDS

Range gear shift lever	km/h (mph)
Low	13 (8)
High	60 (37)
Reverse	16 (10)



## Specifications

# VEHICLE LIMITATIONS

The Vehicle has been thoroughly tested for proper performance with implements sold or approved by manufacturer. Use with implements which are not sold or approved and which exceed the maximum specifications listed below, or which are otherwise unfit for use, vehicle may result in vehicle malfunction or failures with a possibility of the vehicle damage to other property and injury to the operator or others, [Any malfunctions or failures of the vehicle resulting from use with improper implements are not covered by the warranty]

<b>Max. Cargo loading weigh</b>	
Cargo Bed Capacity=159kg(350lb) Vehicle Total Capacity=399kg(880 lb)	Max. rolling weight 544kg (1200 lbs.)
*(operator+ one passenger+ opt+ acc )weight+ trailer weight	Max. tongue weight 50kg (110lbs.)

1. Above mentioned specifications are based on level ground condition.

# Pre-Operation

## DAILY CHECK

To better prevent issues, familiar yourself with the operation of the vehicle prior to driving.



### CAUTION:

To avoid personal injury:

**Be sure to check and service the vehicle on a level surface with the engine shut off and the parking brake set. Ensure that engine temperature has cooled down prior to any work performed.**

#### Check items

- Check Pre-Ride checklist on page 9-3 prior to operating vehicle.
- Review all warning and caution labels for compliance prior to operating vehicle.

# Operating the Engine

## CAUTION:

To avoid personal injury:

- Read "SAFE OPERATION" in front of this manual.
- Read the danger, warning and caution labels located on the vehicle.
- To avoid the danger of exhaust fume poisoning, do not operate the engine in closed buildings without proper ventilation.
- Start engine only from operator's seat. Never start engine while standing on ground.
- Make it a rule to set gear shift lever to "NEUTRAL" position before starting the engine.

## IMPORTANT:

- Do not use starting fluid or ether.
- To protect the battery and the starter, make sure that the starter is not continuously turned for more than 5 seconds.

## STARTING THE ENGINE

### 1. Make sure the parking brake is set.

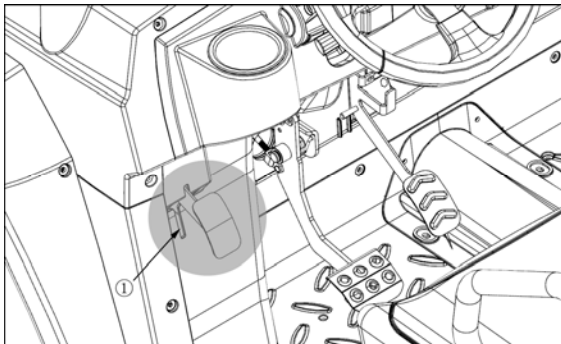

① Parking brake

## NOTE:

The parking brake warning lamp (P) comes on while parking brake is applied and goes off when it is released.

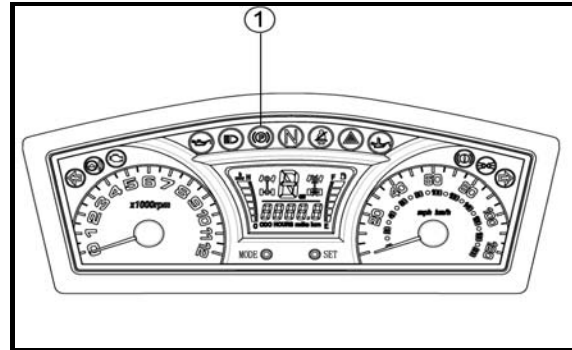

① Parking brake warning lamp

### 2. Set gear shift lever to the "NEUTRAL" position.

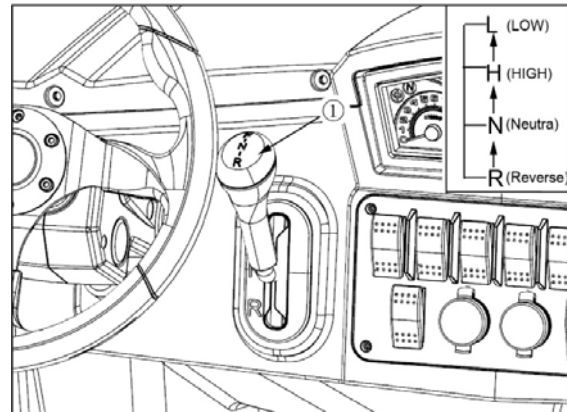

① Range gear shift lever.

- (L) Low Range
- (H) High Range
- (N) Neutral position
- (R) REVERSE

# Operating the Engine

## 3. Push the accelerator pedal down slowly.

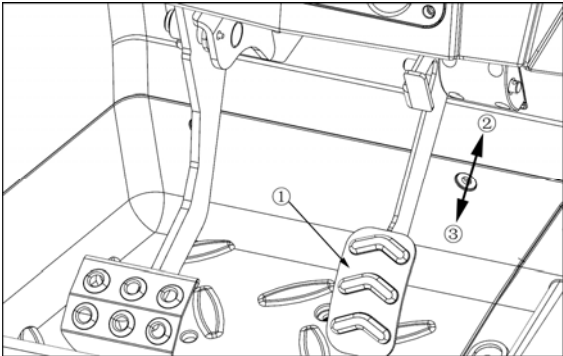

① Speed control pedal

②=>③ INCREASE

③=>② DECREASE

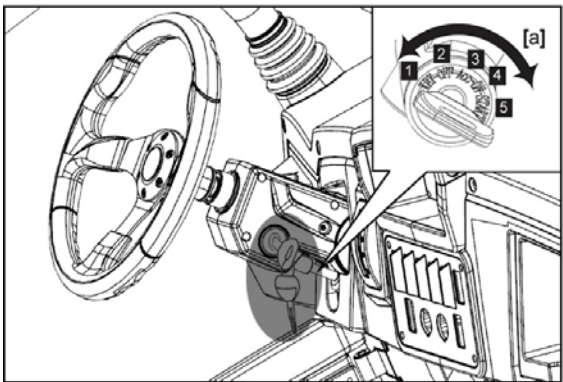

1. Insert the key into the key switch and turn it "START".

OFF (Stop the Engine)

ON (Engine runs or headlights on)

START (Start the Engine)

### IMPORTANT :

- It is not sufficient to do daily checks on dash board only. Always conduct daily checks carefully by referring to "DAILY CHECK" in "PERIODIC SERVICE" section.

4. Turn the key to "START" position and release when the engine starts.

### IMPORTANT:

- Because of safety devices, the engine will not start except when the gear shift lever is placed in the "NEUTRAL" position and the brake is depressed.

### ■ Cold Starting

When the ambient temperature is below - 15°C ( 5°F), the engine is very cold. If the engine fails to start after 5 seconds, turn off the key for 30 seconds and start again.

## STOPPING THE ENGINE

1. After slowing the engine to idle, turn the key to "OFF".
2. Remove the key.

## VEHICLE WARM UP

### ⚠ CAUTION:

To avoid personal injury:

- Be sure to set the parking brake during warm-up.
- Be sure to set the shift lever to the warming up engine.

For 5 minutes after engine start-up, allow the engine to warm up without applying any load. This is to allow sufficient oil protection for all internal wear components. If load applied to the engine without warming-up, engine damage may occur.

### ■ Warming Up Transmission

### IMPORTANT:

- Do not operate the vehicle under full load condition until it is sufficiently warmed up.

# Operating the Vehicle

## OPERATING NEW VEHICLE

How a new vehicle is handled and maintained determines the life of vehicle.

A new vehicle just off the factory production line has been, of course, tested, but the various parts are not aligned to each other, so the operator should pay more attention to operating the vehicle for the first 50 hours at a slower speed and avoid excessive work or operation until the various parts become "broken-in." The manner to which you handle the vehicle during "breaking-in" period greatly affects the life of your vehicle. Therefore, to obtain the maximum performance and the longest life of the vehicle, it is very important to properly break-in your vehicle. For better handling a new vehicle, the following precautions should be observed.

### ■ Do not operate the vehicle at full speed for the first 50 hours.

- Do not start quickly nor apply the brakes suddenly.
- In winter, operate the vehicle after fully warming up the engine.
- Do not run the engine at speeds faster than prescribed.
- On rough roads, slow down to suitable speeds.

Do not operate the vehicle at fast speed. The above precautions are not limited to new vehicles. However, they should be especially observed for new vehicles.

## ■ Changing Lubricating Oil for New Vehicles

The lubricating oil is especially important for a new vehicle. Various parts need time to wear and polish themselves to the correct operating clearances. Small pieces of metal grit may develop during the operation of the vehicle; and this may wear out or damage the parts. Therefore, change the lubricating oil a little earlier than would ordinarily be required. For further details of change interval hours, see "MAINTENANCE" section

## STARTING

### 1. Fasten the seat belt during operation.

#### ■ Seat Belt

### WARNING

To avoid personal injury:

- **Seat belts reduce injury. Always wear your seat belts. The lap-style seat belts may not provide adequate protection for small children. Pay special attention when carrying a child passenger.**

### CAUTION:

To avoid personal injury:

- **Always use the seat belts when operating and riding the vehicle.**

Adjust the seat belts for proper fit and connect the buckle. This seat belt is an auto-locking retractable type.

# Operating the Vehicle

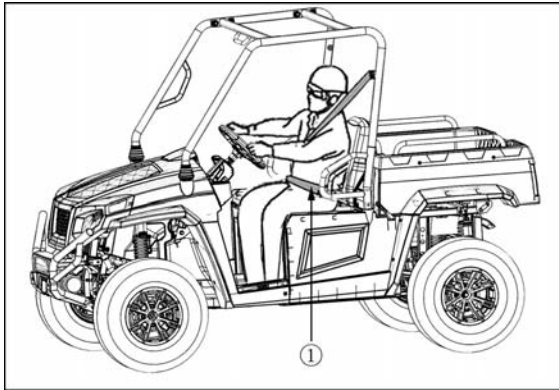

① Seat belt

## 2. Selecting light switch position.

### ■ Head Light Switch

Turn on the key switch and toggle the head light switch to the "ON" position.

Toggle the head light switch to the "OFF" position to turn off the head light.

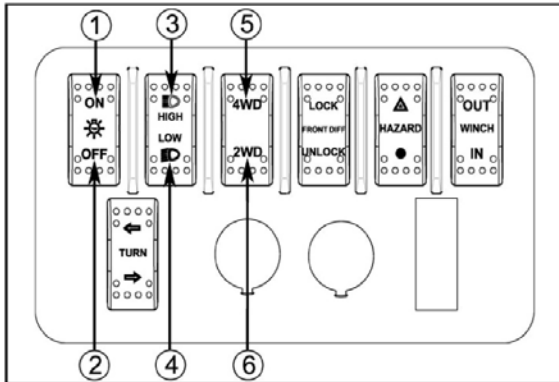

- ① Head light switch
- ② Head lights "OFF"
- ③ High beam lights "ON"
- ④ Low beam lights "ON"
- ⑤ 4WD button
- ⑥ 2WD button

### NOTE:

Turning the head light switch to the "ON" position causes the following lamps to light simultaneously.

1. Tail lights (lamps at the rear portions of the vehicle)
2. Lamp built in the coolant temperature gauge
3. Lamp built in the fuel gauge
4. Lamp built in the speedometer
5. Front left and right position lights

### ■ Hazard Light Switch

[if equipped]

Press the hazard switch to the up position to turn on the hazard lights. This will turn on the blinking turn signals and audible alarm will sound.

### Note:

The emergency light switch will operate when the key switch is in the "ON" position. Be careful that keeping the switch "ON" causes the battery to run out.

### ■ Turn Signal Light Switch

[if equipped]

To indicate a right turn, push on the lower half of the turn toggle switch.

To indicate a left turn, push on the upper half of the turn toggle switch.

When the left or right signal is activated, the indicated turning light will flash and the other will stay on.

The indicator lamp at the instrument panel also flashes indicating the direction of the turn.

### NOTE:

- The turn signal light switch is only operational when the key switch is in the "ON" position.

If the hazard light switch is switched to the "ON" position while the turn signal is



# Operating the Vehicle

activated, the indicated turning light will flash and other will stay on.

- Be sure to return switch to center position after turning.

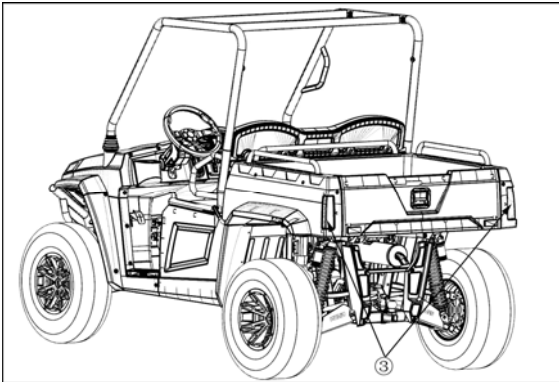
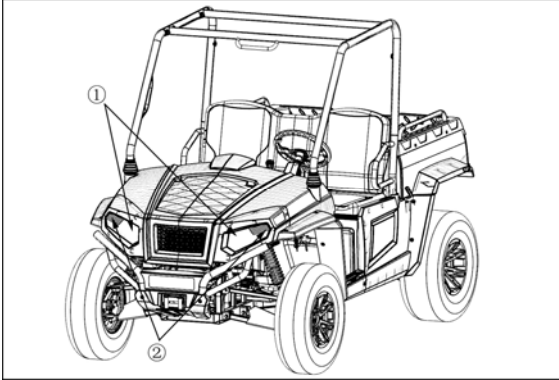

- ① Head light      ② Head turn signal lamp;  
③ Tail turn signal lamp

### 3. Checking the brake pedal.

#### ■ Brake Pedal

#### CAUTION:

To avoid personal injury:

- If the operator suddenly brakes, an accident may occur due to loss of control or the shifting forward of heavy loads.

**When driving on icy, wet or loose surface, make sure the vehicle is correctly loaded to avoid skidding or loss of steering control.**

#### Reduce the speed.

The brake pedal is the left pedal on the foot board. Depress the pedal to slow or stop the vehicle.

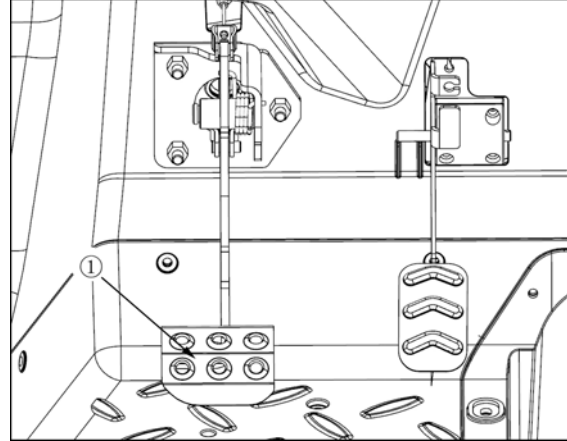

- ① Brake pedal

### 4. Selecting the travel speed.

#### ■ Range Gear Shift Lever

#### CAUTION:

To avoid personal injury:

- Avoid changing gears when ascending or descending a slope.
  - Before ascending or descending a slope, shift to the “L” range to control the vehicle speed.
  - If you shift gears while ascending or descending a slope, be prepared to use the brake to maintain control.
  - Operate in reverse at slow speeds to maintain control.
1. The range gear shift lever can only be shifted only when the vehicle is completely stopped and the the brake pedal is pressed.
  2. To avoid transmission and shift linkage damage, completely stop the vehicle prior to changing gear rang or direction.

# Operating the Vehicle

3. Select proper gear and engine speed depending on the type of job.
4. Before exiting vehicle, shift the gear shift lever to the "NEUTRAL" position and set parking brake.

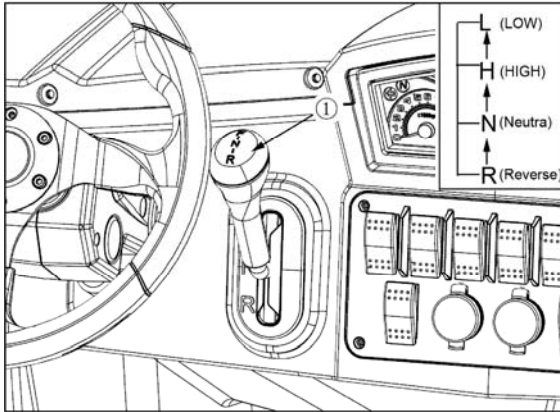

- ① Range gear shift lever
- (L) LOW Range
  - (H) HIGH Range
  - (N) "NEUTRAL" POSITION
  - (R) "REVERSE"

## NOTE:

- When range gear shift lever is hard to engage, do not force the lever. Set the parking brake, slightly depress the accelerator pedal and release it to neutral position, then shift the lever. When the lever is hard to disengage, do not force the lever.
- Depress the brake pedal fully, then shift the lever. Damage may occur with wrong shifting operation.

## ■ 4WD Lever



## CAUTION:

To avoid personal injury:

- when traveling at road speed. Use only 2WD.
- When driving on icy, wet or loose surfaces, make sure the vehicle is correctly loaded to avoid skidding and loss of steering control. Reduce the speed and engage front wheel drive.
- Accident may occur if the vehicle is suddenly braked, such as heavy towed loads shifting forward causing loss of control.
- The braking characteristics are different between two and four wheel drive. Be aware of the difference and operate carefully.

## 5. Unlock the parking brake and start slowly.

To release the parking brake, depress the brake pedal. Make sure that indicator in the display goes off.

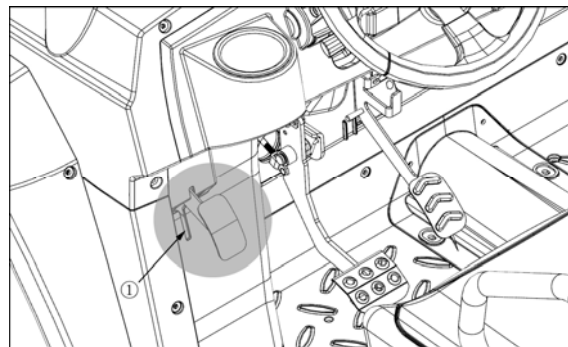

- ① Parking brake

# Operating the Vehicle

## ■ Accelerator Pedal

The accelerator pedal is used to increase the engine and vehicle speed. Push down on it for higher speed.

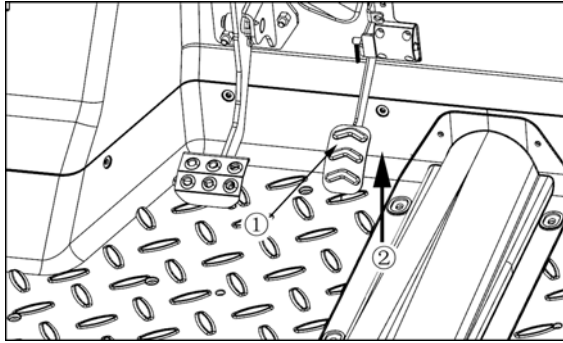

① Accelerator pedal

## STOPPING

### ■ STOPPING

1. Release the accelerator pedal
2. Step on the brake pedal.

## CHECK DURING DRIVING

### ■ Immediately Stop the Engine if:

- The engine suddenly slows down or accelerates.
- Unusual noises are suddenly heard.
- Exhaust fumes suddenly become very white.

While driving, check the following items to see if all parts are functioning normally.

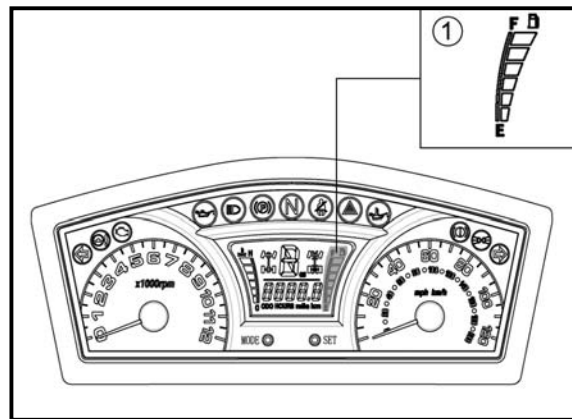
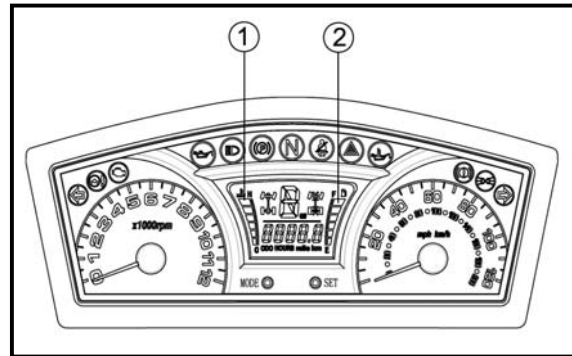

① Fuel gauge

### ■ Coolant Temperature Gauge

## ⚠ CAUTION:

To avoid personal injury:

- Do not remove radiator cap until coolant temperature is well below its boiling point. Then loosen cap slightly to relieve pressure before removing cap completely.
1. With the key switch "ON" the temperature gauge indicates the temperature of the coolant. White Zone for "cold" and Red zone for "hot".
  2. If the indicator reaches the Red zone, the engine coolant is overheated. Check the vehicle by referring to "TROUBLESHOOTING" section.

# Operating the Vehicle

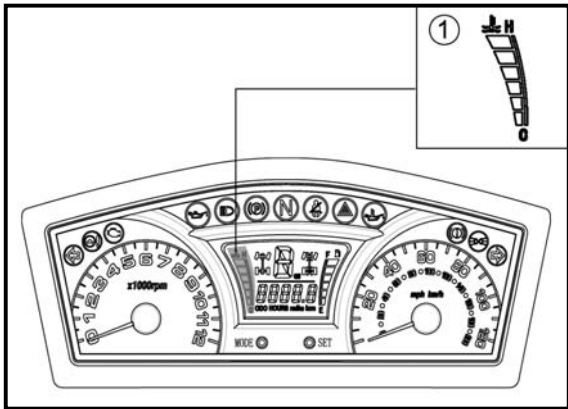

① Coolant temperature gauge

The hourmeter indicates in five digits the hours the vehicle has been used; the last digit indicates 1/10 of an hour.

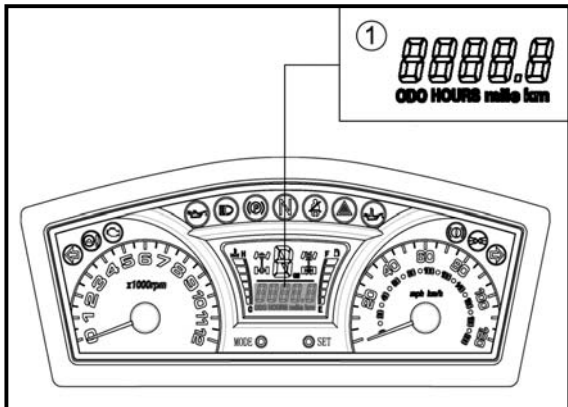

① Hourmeter

The speedometer indicates the traveling speed.

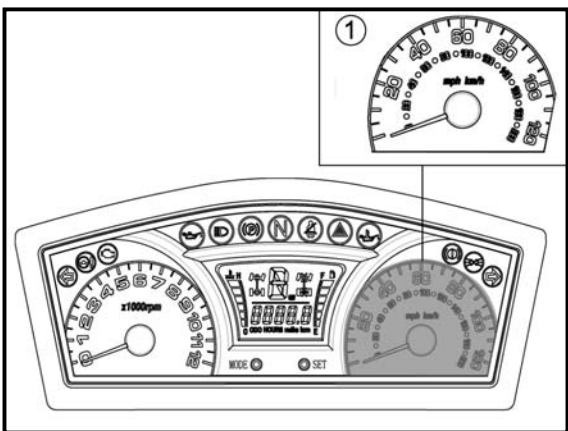

① Speedometer

# Maintenance and Adjustment

## WINCH OPERATIONS

Always read and follow the instructions in the winch owner's manual before attempting to install or use a winch.

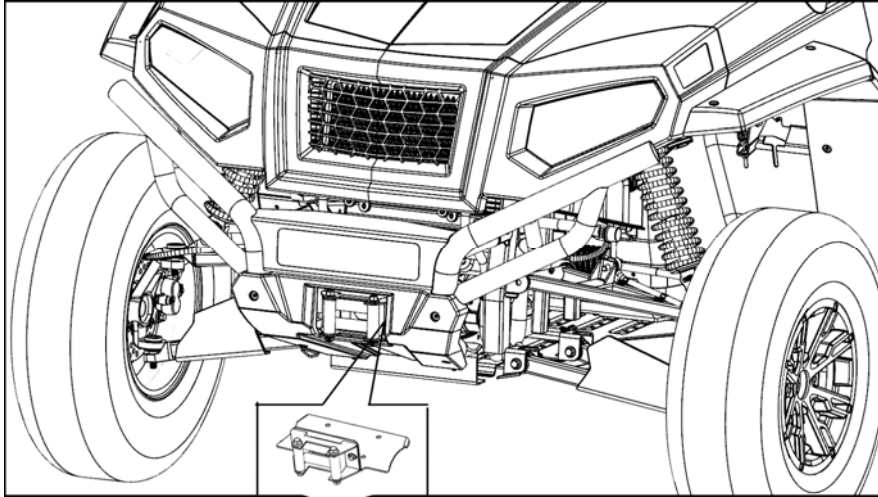

① Winch mount plate

### ■ Transporting Vehicle

Pay attention to the following points when transporting the vehicle.

1. Use a suitable truck and trailer.
2. Apply the parking brake and properly secure vehicle to trailer.

# Maintenance and Adjustment



## CAUTION:

To avoid personal injury and vehicle damage:

- Be sure you have sufficient knowledge, experience, the proper replacement parts and tools before you attempt any vehicle maintenance task.
- If you don't have the knowledge and equipment which are necessary to perform the maintenance task, consult your local dealer.

## SERVICE INTERVALS

ITEM	MAINTENANCE INTERVAL (WHICHEVER COMES FIRST)			REMARKS
	Hours	Frequency	Miles (KM)	
<b>Pre-Ride Inspection Check</b>				
Steering	-	Pre-Ride	-	Inspect for loose hardware or abnormal wear
Front-suspension	-	Pre-Ride	-	Inspect for loose hardware or abnormal wear
Rear-suspension	-	Pre-Ride	-	Inspect for loose hardware or abnormal wear
Tires	-	Pre-Ride	-	Proper tire pressure
Brake fluid level	-	Pre-Ride	-	Inspect and add if needed
Brake pedal travel	-	Pre-Ride	-	See Owner's Manual
Brake systems	-	Pre-Ride	-	Make adjustments as needed.
Lug Nuts	-	Pre-Ride	-	Ensure lug nuts are torque to spec
Frame fasteners	-	Pre-Ride	-	All fasteners are secured
Engine Oil Level	-	Pre-Ride	-	Inspect and add if needed
Coolant	-	Pre-Ride	-	Inspect and add if needed
Head / Tail / Brake Lights	-	Pre-Ride	-	Check operation
ITEM	MAINTENANCE INTERVAL (WHICHEVER COMES FIRST)			REMARKS
	Hours	Frequency	Miles (KM)	
<b>Break-In Maintenance Check</b>				
Engine Oil/Filter change	10	-	First 50 (75)	Replace break-in oil & filter with proper oil type
Transmission	20	-	First 100 (150)	Initial fluid level inspection; add lubricant if needed
Toe adjustment	20	-	First 100 (150)	Inspect periodically; adjust when parts are replaced
Clutches (Drive and Driven)	20	-	First 100 (150)	Inspect; clean; replace worn parts

# Maintenance and Adjustment

ITEM	MAINTENANCE INTERVAL (WHICHEVER COMES FIRST)			REMARKS
	Hours	Frequency	Miles (KM)	
<b>Routine Maintenance Check</b> (performed at each interval below, whichever comes first)				
Air filter	5 H	-	-	Inspect; replace as needed
Brake pad wear	20 H	Monthly	250 (402)	Inspect periodically
Throttle Body Intake	20 H	1 M	250 (402)	Inspect duct for proper sealing/air leaks
Battery	20H	Monthly	250 (402)	Check terminals; clean; test
Fuel System	25 H	Monthly	250 (402)	Check lines & fittings for leaks
General lubrication	25H	3 M	250 (402)	Lubricate all fittings, pivots, cables, etc.
Shift Linkage	25H	3 M	250 (402)	Inspect, lubricate, adjust
Engine Oil & Filter	50 H	6 M	500 (800)	Replace
Steering	50 H	6 M	500 (800)	Lubricate
Front / Rear Gearcase Fluid	50H	6 M	500 (800)	Change Fluid
Front / Rear Stabilizer Bars	50H	6 M	500 (800)	Lubricate and inspect bushings
Throttle Pedal/Cable	50 H	6 M	500 (800)	Inspect for free movement & lubricate
Drive Belt	50 H	6 M	500 (800)	Inspect; replace as needed
Antifreeze Coolant	50 H	6 M	500 (800)	Pressure Test / Add Fluid
Transmission Fluid	50 H	6 M	500 (800)	Replace
Engine mounts	100 H	12 M	1000 (1600)	Inspect; replace as needed
Cooling Hoses	100 H	12 M	1000 (1600)	Inspect for cracks and leaks
Drive Shafts	100H	12M	1000 (1600)	Remove and grease
Spark plug	100 H	12 M	1000 (1600)	inspect; replace as needed
Clutches (Drive and Driven)	100 H	12 M	1000 (1600)	Inspect; clean; replace worn parts
Wiring	100 H	12 M	1000 (1600)	Inspect for wear & routing
Wheel Bearings	100 H	12 M	1000 (1600)	Inspect; replace as needed
Shocks	100 H	12 M	1000 (1600)	Check for oil leaks
Cam Chain Tensioner	100H	12 M	1000 (1600)	Check; replace as needed
Brake Fluid	100 H	12M	1000 (1600)	Change every two years
Suspension Components	100H	12M	1000 (1600)	Inspect; replace if necessary
Spark arrestor	100H	12 M	-	Clean out
Valve clearance	100 H	12M	1000 (1600)	Inspect; adjust
<b>Extreme Maintenance Check</b> (cut the Routine Maintenance Schedule in half)				
* <b>Service Note:</b> Under extreme use, change gear case fluid every 25 hours. "Extreme Use" is defined as constant <u>4WD</u> operation on hilly or mountainous terrain, or if 4WD is the primary mode of operation.				

# Maintenance and Adjustment

## **LUBRICATION RECOMMENDATIONS**

Check and lubricate all components at the intervals outlined in the Periodic Maintenance Chart above, or more often under severe use, such as wet or dusty conditions. Items not listed in the chart should be lubricated at the general lubrication interval.

<b>ITEM</b>	<b>LUBE</b>	<b>METHOD</b>
Engine Oil	See Viscosity Chart (10-3) API-SJ & JASO/MA	Add to proper level on dipstick.
Brake Fluid	DOT 3 or 4 Brake Fluid	Maintain level between fill lines.
Rear Differential	SAE 80w90	Fill to bottom of fill plug or 0.455L or 14 oz.)
Front Differential	Dextron 3 ATF	Fill to bottom of fill plug or (volume of oil)
Drive Shaft	U-Joint Grease	Locate fittings and grease.

## **ENGINE OIL**

Always check and change the oil at the intervals outlined in the Service Interval Chart above. Always use the recommended engine oil. Always change the oil filter whenever changing oil.

Vehicle operation with insufficient, deteriorated, or contaminated engine oil will cause accelerated wear and may result in engine seizure, accident and injury.

Always perform the maintenance procedures as outlined in the Periodic Maintenance Chart. Failure to perform routine maintenance could result in voiding of remaining warranty.



# Periodic Service

## CAUTION:

To avoid personal injury:

## HOW TO OPEN THE FRONT HOOD COVER AND SEAT

### CAUTION

To avoid personal injury from contact with moving parts:

- Never open operator's seat while the engine is running.

#### ■ Front hood cover

To open the hood, turn the switch as the direction in below picture to release the latch and lift the hood off. To close, tilt cover back to closed position and fasten the latches.

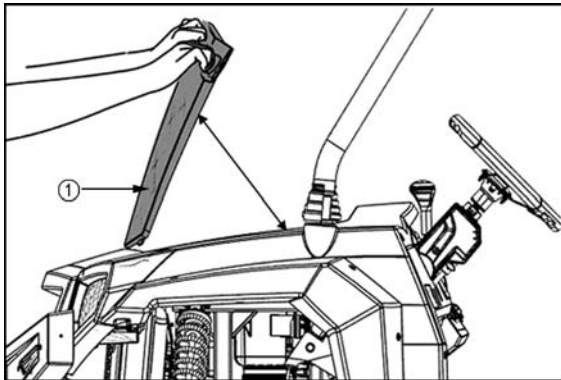
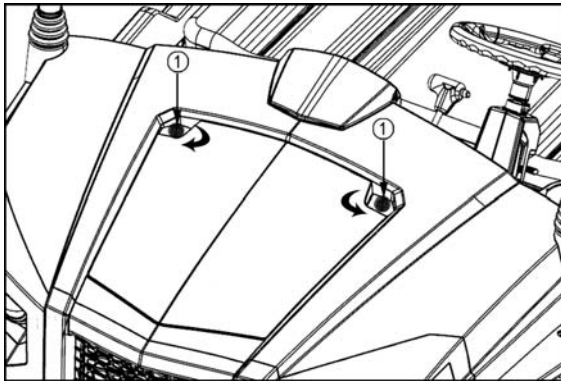

- ① Turn switch
- ② Front hood cover

#### ■ Operator's Seat

To open the seat, raise the seat to the forward position.

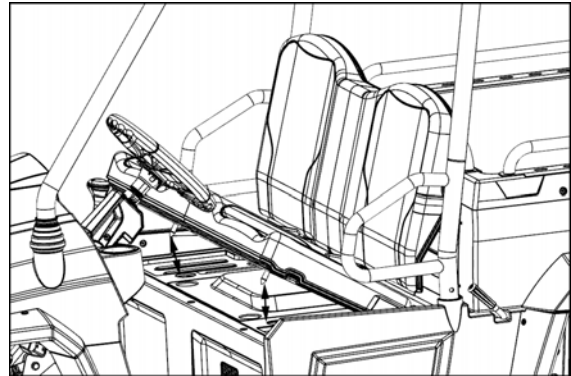

- ① Operator's seat

## HOW TO RAISE THE CARGO BED

### CAUTION

To avoid personal injury:

- When servicing under raised bed, make sure safety support is properly mounted.
- Do not touch muffler or exhaust pipes while they are hot; Otherwise, severe burns could result.

#### ■ Raising and Lowering the Cargo Bed

##### ◆ To raise the cargo bed

1. Apply the parking brake with the engine off.
2. Pull up the cargo bed handle.

##### ◆ To lower the cargo bed

Press down on the cargo bed hard to make the gas spring compress until bed is securing locked.

# Periodic Service

## NOTE:

Pull up the cargo bed handle to raise the cargo bed with the gas spring elasticity.

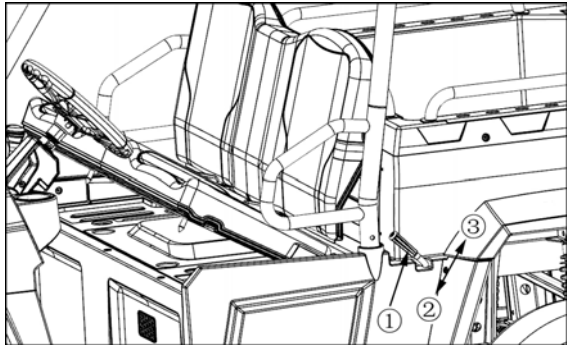

- ① Cargo bed handle
- ② UP
- ③ DOWN

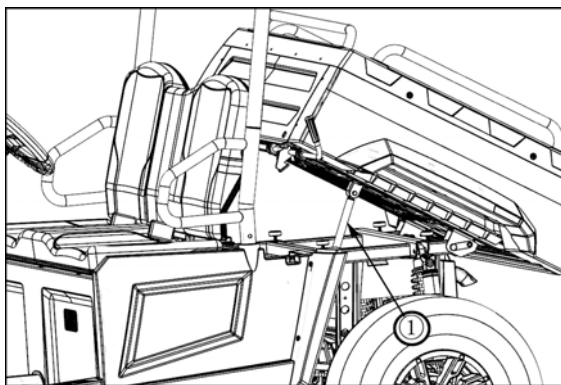

- ① Gas spring

## JACK-UP POINT



## WARNING

To avoid personal injury, death or vehicle damage:

- Do not work under the vehicle unless it is secured by safe stands or suitable blocking.

## ■ Front End

Jack up at the front frame tube only.

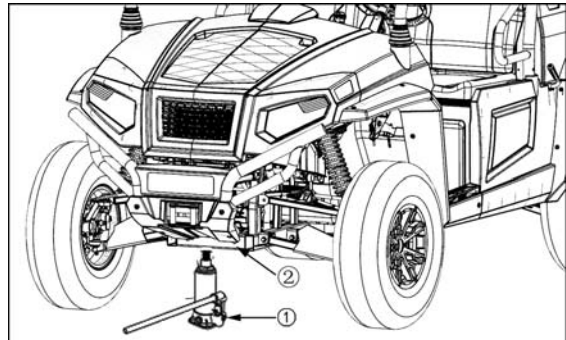

- ① Jack
- ② Front frame tube

## ■ Rear End

Jack the rear only after placing a wooden block under the right and left frame tubes for securing the engine and then supporting it.

Do not apply jack pressure on the steel plate directly under the engine.

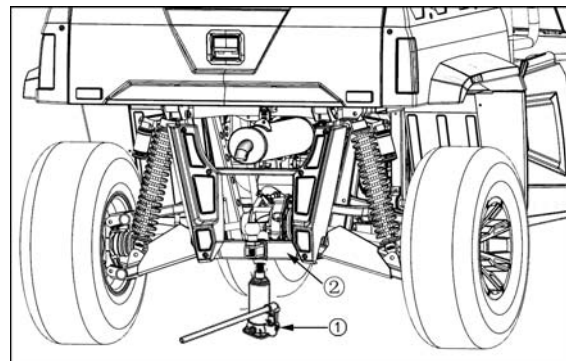

- ① Jack
- ② Rear frame tube

## DAILY CHECK

For your own safety and maximum service life of the vehicle, make a thorough daily inspection before starting the engine and operating the vehicle.

# Periodic Service

## CAUTION

To avoid personal injury:

- Be sure to park the vehicle on a flat surface with the engine off and the parking brake "ON".

### ■ Walk Around Inspection

Look around and under the vehicle for such items as loose bolts, trash build-up, oil or coolant leaks, broken or worn parts

### ■ Checking and Refueling

## CAUTION

To avoid personal injury:

- Do not smoke while refueling.
  - Be sure to stop the engine before refueling.
1. Turn the key switch to "ON", check the amount of fuel by the fuel gauge
  2. Fill fuel tank when fuel gauge shows 1/4 or less fuel in tank.

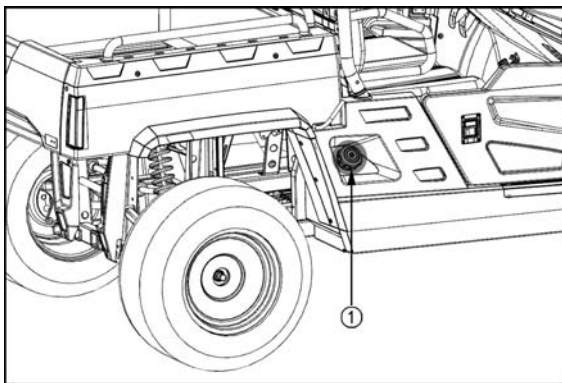

① Fuel tank cap

Fuel tank capacity	28L (7.4 ± 0.1 U.S. GALS)
--------------------	---------------------------

## IMPORTANT

If oil level is low, do not run engine.

Checking engine oil level

1. Park the vehicle on a flat surface with engine off, raise the cargo bed, mount the safety support.
2. To check the oil level, draw out the dipstick, wipe it clean, replace it, and draw it out again, check to see if the level is too low, add new oil to the prescribed level on the dipstick.

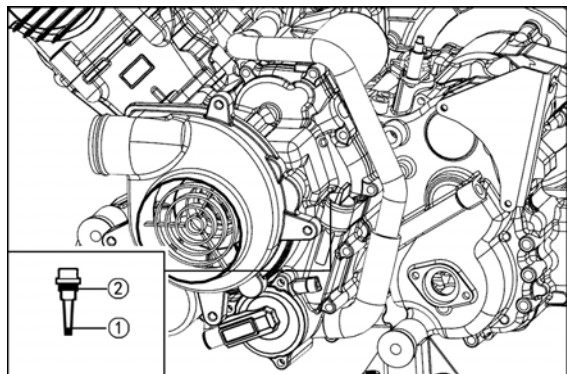

① Oil Level      ② Dipstick

3. See Figure for oil recommendations.

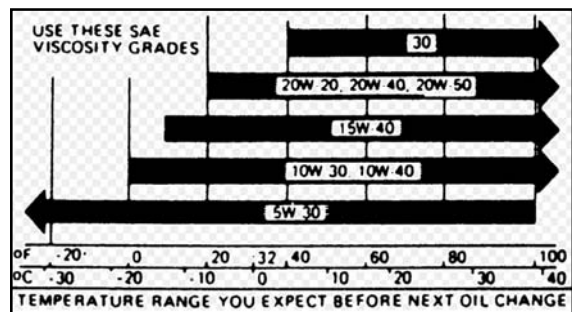

## IMPOTTANT

If oil level is low, do not run engine

### ■ Checking Coolant Level

## CAUTION

TO avoid personal injury

# Periodic Service

- Do not remove radiator cap while coolant is hot . Allow sufficient time for engine and coolant to cool prior to removing the cap.

1. Park the vehicle on a flat surface, access the panel under the hood, set the parking brake, and shut off the engine.
2. Check to see that the coolant level is between the "FULL" and "LOW" marks of recovery tank.
3. When the coolant level drops due to evaporation, add water only up to the full level. In case of leakage add anti-freeze and water in the specified mixing ratio up to the full level. (see flush cooling system and changing coolant in EVERY 2 YEARS in PERIODIC SERVICE section)

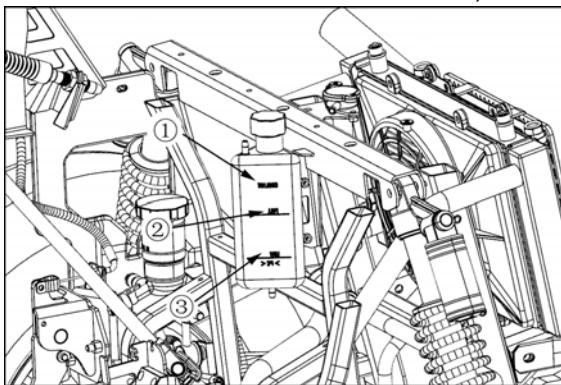

- ① Recovery tank
- ② FULL
- ③ LOW

## IMPORTANT

- If the radiator cap has to be removed, follow the cautions above and securely retighten the cap.
- Use clean fresh water and anti-freeze to fill the recovery tank.  
If water should leak, consult your local HSUN Dealer.

## ■ Cleaning radiator screen

### ⚠ CAUTION

TO avoid personal injury:

- Be sure to stop the engine before removing the screen

1. Park the vehicle on a flat surface, Remove the radiator cover,
2. Remove the radiator cover,
3. Detach the screen and remove all foreign materials,

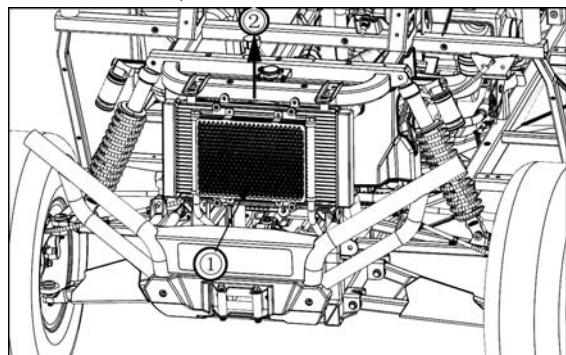

- ① Radiator screen

## IMPORTANT

- Radiator screen must be cleaned from debris to prevent engine from overheating

## ■ Checking brake fluid level

### ⚠ CAUTION

TO avoid personal injury:

- Never operate the vehicle if the brake fluid is below the minimum mark.

Use only DOT3 from a sealed container. Other types of brake fluid may ruin synthetic resin or rubber installed in brake system components and may cause brake failure.

- Avoid contamination of the brake fluid thoroughly by thoroughly cleaning



# Periodic Service

housing prior to removing the filler cap. Do not open the brake fluid reservoir cap unless absolutely necessary.

- Use extreme care when filling the reservoir. If brake fluid spill on power steering hose, wash off with water immediately, as brake fluid quickly ruins synthetic resin or rubber hoses.

1. Check to see that the brake fluid level is up to the LOWER mark.
2. If it is below the "LOWER" mark add brake fluid .

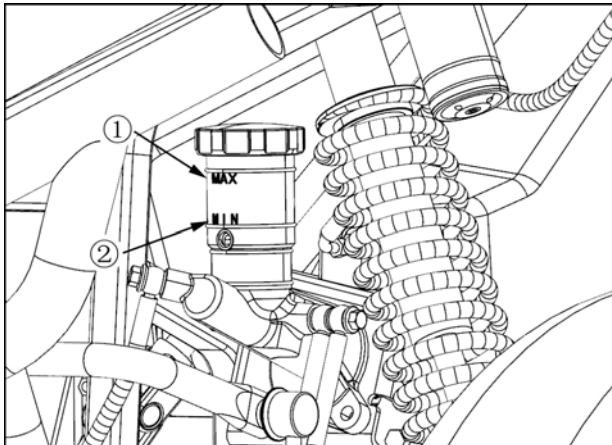

① OIL CUP      ② LOWER

## ■ Checking brake pedal

### ⚠ CAUTION

TO avoid personal injury:

- Stop the engine and chock the wheels before checking brake pedal.

1. Inspect the brake pedals for free play and smooth operation.

Adjust if incorrect measurement is found. (see checking brake pedal in" EVERY 200 HOURS in PERIODIC SERVICE section)

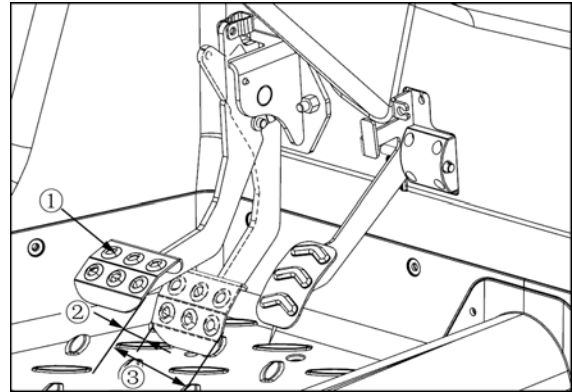

① Brake pedal      ② FREE TRAVEL  
③ PEDAL STROKE

## ■ Checking parking brake

Pull the parking brake to apply the brakes with the key switch in the "ON" position and the parking brake indicator should come on.

To release the parking brake, depress the parking pedal.

Make sure the parking brake warning lamp on the display goes off when parking brake lever is applied.

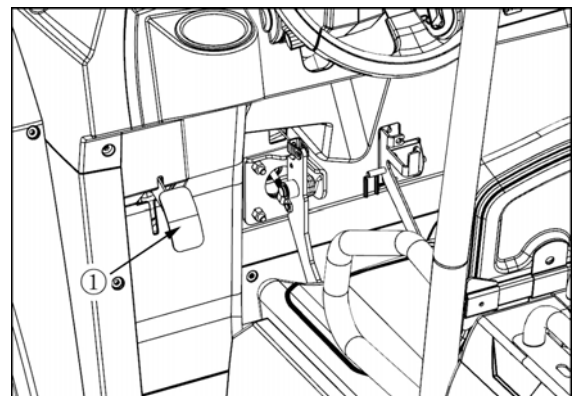

① Parking brake

# Periodic Service

## ■ Checking gauges and indicator lights

1. Inspect the instrument panel for proper operation.
2. Replace if broken.

## ■ Checking head light turn signal light etc

1. Inspect lights for broken bulbs and lenses
2. Replace if broken

## ■ Checking seat belt and ROPS

1. Always check condition of seat belt and ROPS attaching hardware before operating vehicle.
2. Replace if damaged.

## ■ Checking joint boot

1. Check to see if the joint boots are damaged or not.
2. If the boots are torn or show signs of deterioration, consult your local dealer.

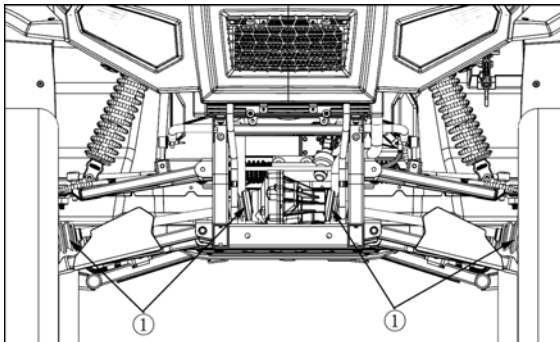

- ① Joint boot      ② Drive shaft

## ■ Checking tire inflation pressure

Though the tire pressure is factory-set to the prescribed level, it naturally drops slowly in the course of time, thus check it every day and inflate as necessary.

tire sizes		inflation pressure
Front:	25x8-12	100kPa (1.0kgf/cm <sup>2</sup> , 14psi)
	26x9-12	
Rear:	25x10-12	110kPa (1.1kgf/cm <sup>2</sup> , 16psi)
	26x10-12	

## EVERY 50 HOURS

### ■ Greasing

Apply a small amount of multi-purpose grease to the following points every 50 hours. If you operated the vehicle in extremely wet and muddy conditions lubricate grease fittings more often.

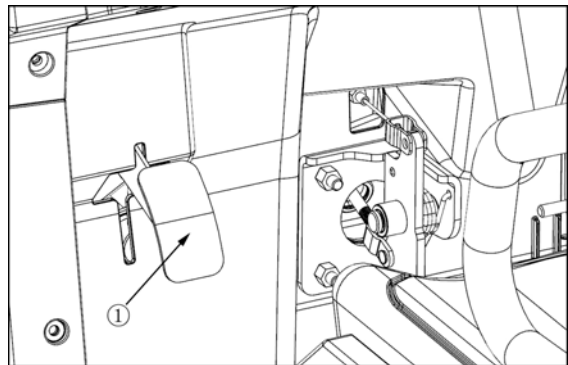
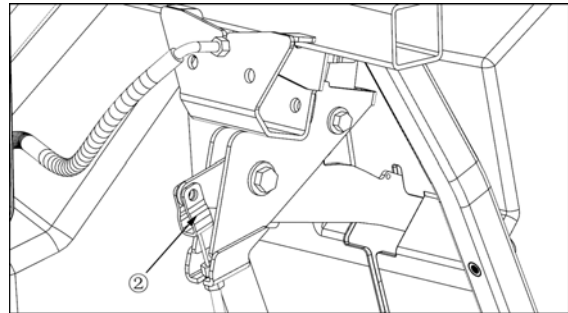

- ① Parking brake  
② Parking brake pivot ( spray type grease )

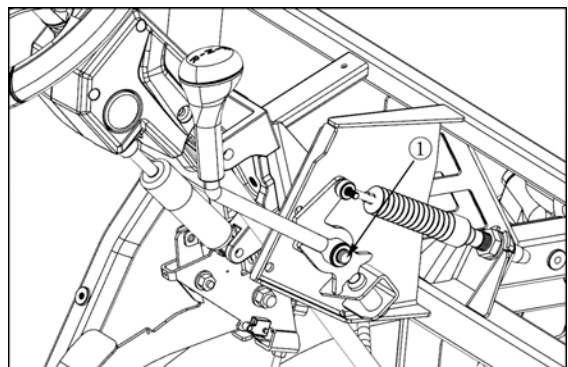

- ① Range gear shift lever pivot (spray type grease )

# Periodic Service

## ■ Checking engine start system

### ⚠ CAUTION

TO avoid personal injury

- Do not allow anyone near the vehicle while testing.
- If the vehicle does not pass the test, do not operate the vehicle.

### ◆ Preparation before testing

1. Place all control levers in the “NEUTRAL” position.
2. Set the parking brake and stop the engine.

### ◆ Test gear shift range lever safety switch

1. Sit on the operator’s seat.
2. Shift the range gear shift lever to: “F”, “N” or REVERSE position.(for HS400UTV-4)  
Shift the range gear shift lever to: “L”, “H”, “N” or REVERSE position. (for HS450UTV)
3. Turn the key to “START” position.
4. The engine must not crank.
5. If it cranks consult your local dealer for this service.

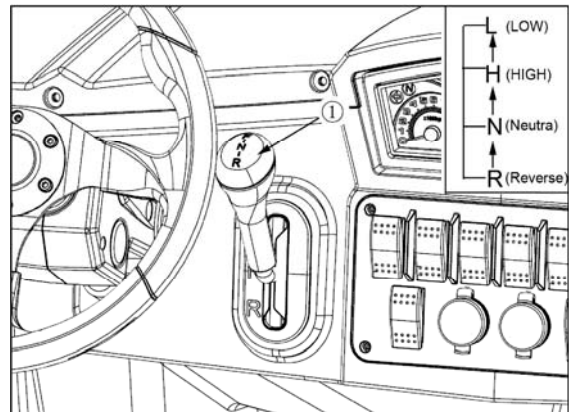

① Range gear shift lever

## ■ Checking wheel bolt torque

### ⚠ CAUTION

To avoid personal injury

- Never operate vehicle with loose wheel bolts.
- Any time these bolts are loosened they should be retightened to the specified torque.
- Check all bolts frequently and keep them tight.

Check wheel bolts regularly especially when new. If they are loose tighten to:

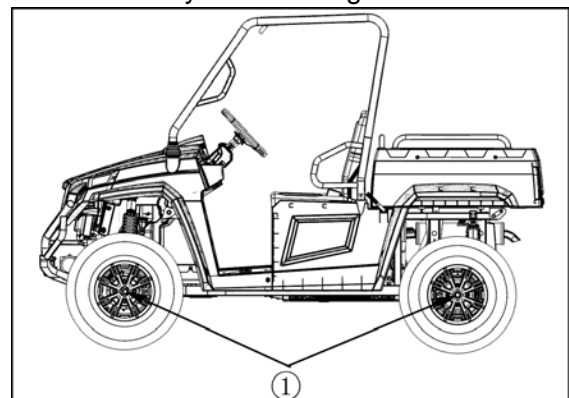

① Torque wheel bolts to 75 to 90 N.m

# Periodic Service

## ■ Cleaning air cleaner primary element

1. Remove the air cleaner cover and primary element.
2. Remove the sponge material from its frame.
3. Wash the sponge material gently but thoroughly in solvent.
4. Squeeze the excess solvent out of the sponge material and let it dry.
5. Inspect the sponge material and replace it if damaged.
6. Thoroughly apply foam air filter oil or other quality liquid foam air filter oil (not spray type) to the sponge material.
7. Re-install the air filter element.
8. Install the air filter case cover and be sure the crankcase breather hose is connected.

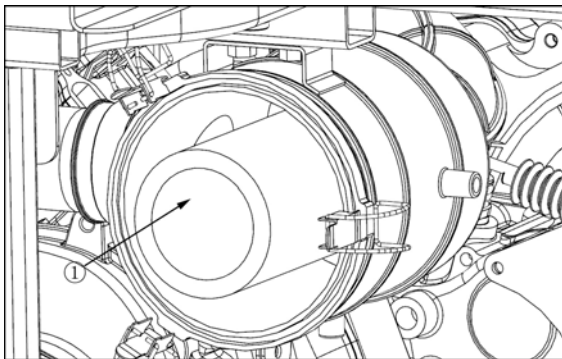

① Air filter element

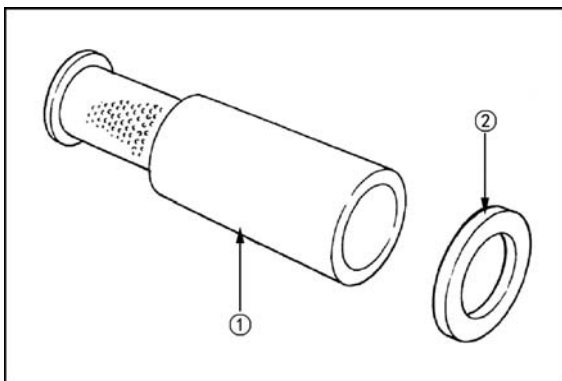

① Air filter element      ② Locating pad

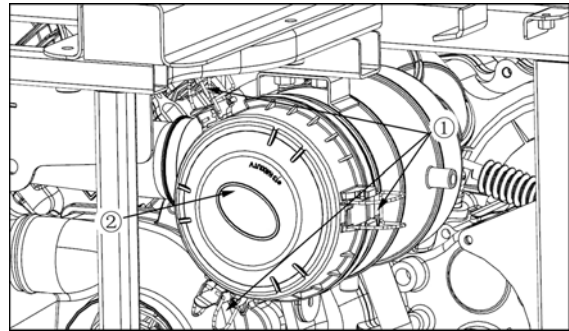

① Mounting point      ② Air filter cover

## IMPORTANT

- The air filter uses a dry element .Never apply oil.
- Do not run the engine with air filter removed.
- Be sure to install cover properly prior to operation. Improper secured cover will allow dirt and air into engine causing idle issues and potentially damage engine.

## ◆ Air Filter Cover

Open the air filter cover once a week under ordinary conditions –or daily when used in a dusty place-to get rid of large particles of dust and dirt.

## ■ Check fuel line and fuel filter



To avoid personal injury:

- Be sure to stop the engine and remove the key when attempting to make the following checks and changes.
- Never fail to check the fuel lines periodically the fuel lines are subject to wear and aging fuel may leak out onto the running engine causing a fire.



## Periodic Service

- **The fuel line connections should be checked annually or every 100 service hours whichever comes first.**

1. Park the vehicle on a flat surface and raise the cargo bed.
2. The fuel line is made of rubber and ages regardless of service period.
3. If the fuel line and clamps are found to be damaged or deteriorated replace them.
4. Check fuel filter if it is clogged by debris or contaminated with water replace it.

### IMPORTANT

When the fuel line is disconnected for maintenance or repair, close both ends of the fuel line with a piece of clean cloth or paper to prevent dust and dirt from entering. Particular, care must be taken not to admit dust and dirt into the fuel pump entrance. Even a small amount of dust or dirt cause premature wear and malfunction of the fuel pump and injector components.

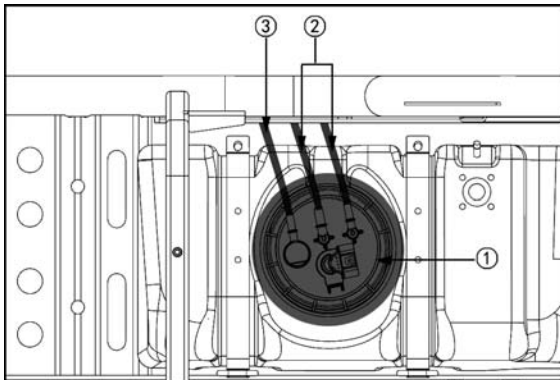

- ① Fuel pump      ② Fuel line  
③ Exit pipe

5. To remove the in-line fuel filter clamps (b), slide the clamps (b) away from the in-line fuel filter (a). Twist and pull the fuel lines off of the in-line fuel filter (a).

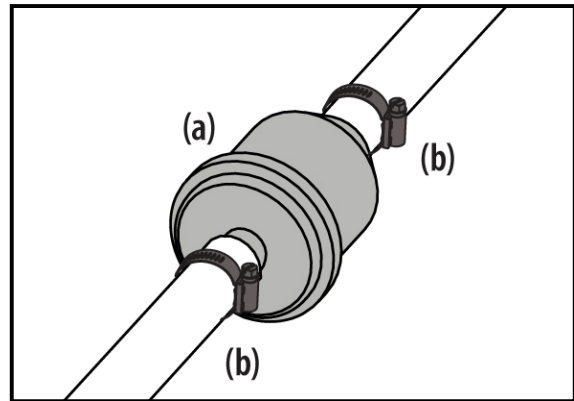

6. Check the in-line filter (a) for debris and/or water contamination. Replace as necessary.

### ■ Checking battery condition



If you store a battery in a diminished state of charge you will probably have to replace the battery.



To avoid personal injury

- Never remove the battery while the engine is running.
- Keep electrolyte away from eyes, hands and clothes. If you are splattered with it, wash it away completely with water immediately and get medical attention.
- Wear eye protection and rubber gloves when working around the battery.

The factory –installed battery is non-refillable type if the battery is weak, charge the battery or replace it with new one.

# Periodic Service

## ◆ Battery charging



To avoid personal injury

- When the battery is being activated, hydrogen and oxygen gases in the battery are extremely explosive. keep open sparks and flames away from the battery at all times, especially when charging the battery.

When disconnecting the cable from the battery start with the negative terminal first; when connection the cable to the battery start with the positive terminal first.

- Always check battery charge by using a voltmeter.

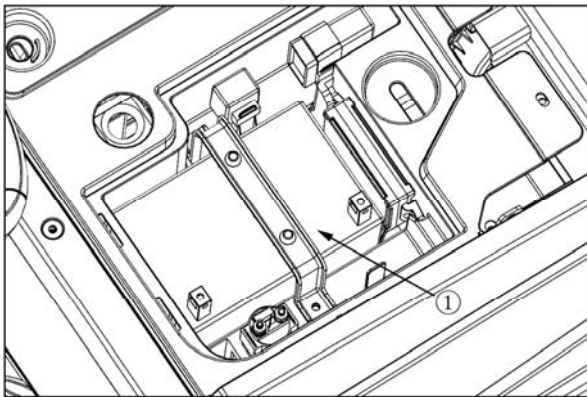

① Battery

1. To slow charge the battery connect the battery positive terminal to the charger positive terminal and the negative to the negative. then recharge in the standard fashion.
2. A boost charge is only for emergencies it will partially charge the battery as early as possible.
3. When exchanging an old battery for a new one use battery of equal specification shown

in table 1.

Battery type	Volts
12volt/300CCA	12

## Direction for storage

1. When storing the vehicle for a long period, remove the battery from the vehicle, store in a dry place out of direct sunlight.

The battery shall self self-discharge while it is shored recharge it once every three months in hot seasons and once every six months in cold seasons.

## ■ Adjusting toe-in

Proper toe-in	0 to12 mm (0 to 0.47 in)
---------------	--------------------------

1. Park vehicle on flat place.
2. Turn steering wheel so front wheels are in the straight ahead position.
3. Lock the park brake and stop the engine.
4. Measure distance between front tire beads at rear of tire at hub height.
5. Front distance should be shorter than rear distance if not adjust tie rod length.

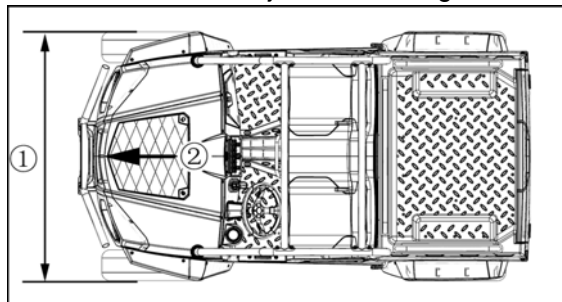

① Wheel-to-wheel distance at front ② FRONT

## ◆ Adjusting procedures

1. Loosen the lock nut and turn the tie rod to adjust the rod length until the proper toe-in measurement is obtained.

# Periodic Service

2. Retighten the lock nut.

## IMPORTANT

- Keep the equal length of the left and right tie-rod.

## ■ Cleaning Muffler



## CAUTION

To avoid personal injury:

Before touching any part of an exhaust system, be absolutely sure that it has sufficient time to cool!

- Always wear safety goggles and face mask.
- The particulate matter contained in the muffler contains chemicals that are harmful to people, animals and marine life.
- If you are unable to do this work, have it done by your dealer.
- Cleaning spark arrester of muffler.

Maintenance & cleanout procedure:

The screen type spark arrester should be removed, cleaned, and inspected after every 100 hours of use.

1. The spark arrester is located inside of the muffler body, and fastened with bolts.
2. Loosen the bolts and remove the spark arrester.
3. Shake loosened particles out of the screen assembly and lightly clean the screen with wire brush. Soak in solvent and again clean with wire brush if necessary.
4. If any breaks in the screen or welds are discovered, the assembly must be replaced.
5. Return the spark arrester to the muffler body and refasten the bolts.

## IMPORTANT:

- Visually check the muffler for cracks or holes in the body, weldment or pipes at regular intervals.
  - USDA approval requires clearance between spark arrester sleeve and muffler body to be no larger than 0.023"(0.584 mm).
  - Replace the entire muffler if it is damaged.
- Do not operate the vehicle with a damaged muffler.

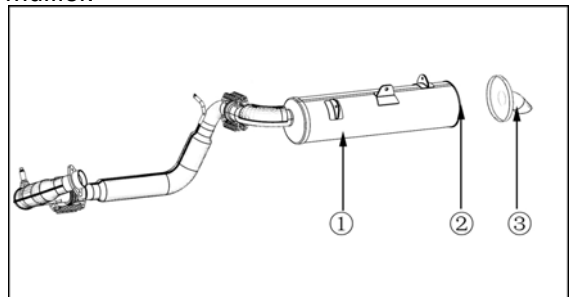

① Muffler    ② Spark arrester    ③ Back cover

## EVERY 200 HOURS

### ■ Changing Engine Oil



## CAUTION

To avoid personal injury:

- Be sure to stop the engine before replacing oil.
  - Allow engine to cool down sufficiently, oil can be hot and can burn.
1. Park the vehicle on flat surface and raise the cargo bed.
  2. To drain the used oil, remove the drain plug at the bottom of the engine and completely drain the oil into an oil pan.
  3. After draining, reinstall the drain plug.
  4. Fill with the new oil up to the upper notch on the dipstick.  
(See "LUBRICANTS, FUEL AND COOLANT" in "MAINTENANCE" section.)

# Periodic Service

Oil capacity	with filter change	2.0L (2.2U.S. qts.)
	without filter change	1.8L (1.89U.S. qts.)

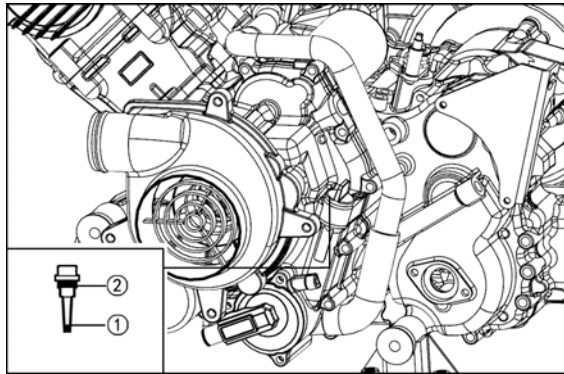

① Oil Lever      ② Dipstick

5. See Figure for oil recommendations.

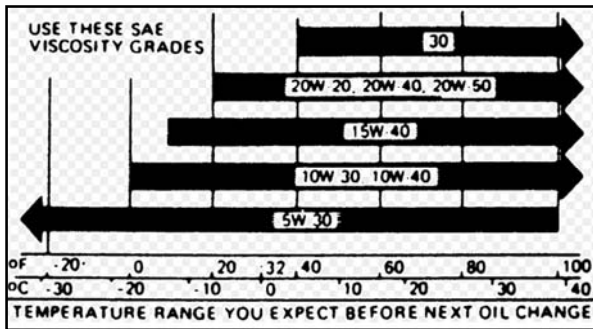

## ■ Replacing Engine Oil Filter

### ⚠ CAUTION

To avoid personal injury:

- Be sure to stop the engine before changing the oil filter cartridge.
- Allow engine to cool down sufficiently, oil can be hot and can burn.

1. Park the vehicle on a flat surface, remove the seat and open the adjust hatch cover.
2. Remove the oil filter.
3. Put a film of clean engine oil on the rubber seal of the new filter.
4. Tighten the filter quickly until it contacts the mounting surface.

Tighten filter by hand an additional 1/2 turn

only.

5. After the new filter has been replaced, the engine oil normally decreases a little. Make sure that the engine oil does not leak through the seal and check the oil level on the dipstick. Then replenish the engine oil up to the prescribed level.

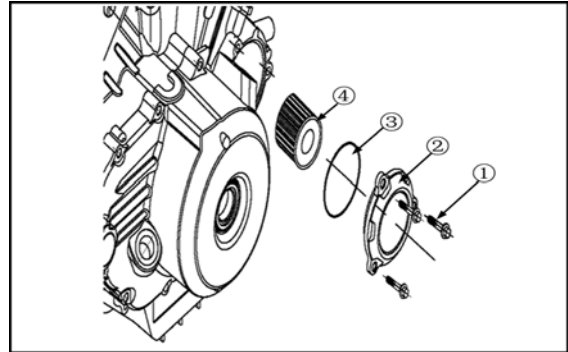

① Bolt;      ② Cover  
③ "O" seal ring;      ④ Engine oil filter

### IMPORTANT:

- To prevent serious damage to the engine, use only a genuine filter.

## ■ Replacing Transmission Oil

### ⚠ CAUTION

To avoid personal injury:

- Be sure to stop the engine before changing oil.
- Allow engine to cool down sufficiently, oil can be hot and can burn.

1. Park the vehicle on a flat surface, raise the cargo bed, and mount the safety support.
2. Put a film of clean transmission oil;
3. Quickly tighten the filter until it contacts the mounting surface, tighten it an additional 1 turn only.
4. After running the engine for a few minutes, stop the engine and check the oil level again. Add oil to the prescribed level.

Oil capacity	[Filter exchanged]	1L (1.05U.S. qts.)
--------------	--------------------	--------------------

# Periodic Service

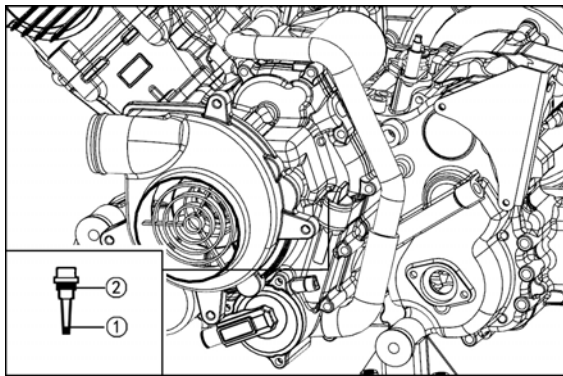

- ① Oil Lever
- ② Dipstick

## ■ Checking Brake Pedal

### ⚠ CAUTION

- Stop the engine and chock the wheels before checking brake pedal.
- If movement is outside of the specifications contact your local dealer for adjusting the brake.

### ◆ Checking the brake pedal free travel

Proper brake pedal free travel	7 to 14mm (0.3 to in.)On the pedal
-----------------------------------	---------------------------------------

1. Release the parking brake.
2. Slightly depress the brake pedal and measure free travel at the top of the pedal stroke.
3. If brake pedal free travel is outside of the specifications, contact your local dealer for adjusting the brake.

### ◆ Checking the brake pedal stroke

Pedal stroke	Less than 120mm (4.7in.) On the pedal
--------------	--

1. Release the parking brake.
2. Step on the pedal and measure the pedal stroke.

3. If brake pedal stroke is outside of the specifications, contact your local dealer for adjusting the brake.

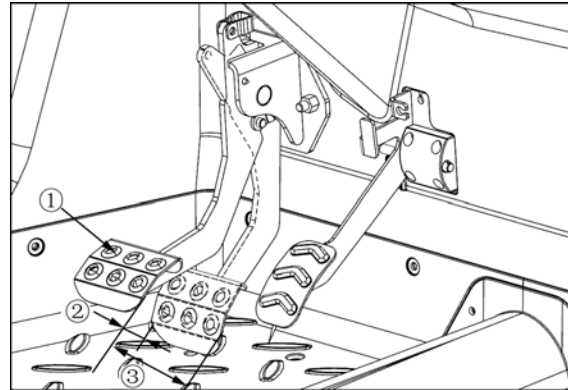

- ① Brake pedal
- ② "FREE TRAVEL"
- ③ "PEDAL STROKE"

## ■ Checking Brake Hose and Pipe

1. Check to see that brake hose and lines are not swollen, hardened or cracked.
2. Check the brake hose and pipe joints for oil leaks.
3. If there is any abnormality, consult your local dealer for this service.

## ■ Checking Brake Light Switch

1. Park the vehicle on a flat surface and raise the cargo bed.
2. Turn the key switch to the "ON" position.
3. Step on the brake pedal to check if the brake light comes on.
4. If it does not, check the bulb or brake light switch.

## ■ Checking Radiator Hose and Clamp

Park the vehicle on a flat surface and raise the cargo bed. Check to see if radiator hoses are properly fixed every 200 hours of operation or



# Periodic Service

six months, whichever comes first.

1. If hose clamps are loose or water leaks, tighten bands securely.
2. Replace hoses and tighten hose clamps securely, if radiator hoses are swollen, hardened or cracked. Replace hoses and hose clamps every 2 years or earlier, if checked and found that hoses are swollen, hardened or cracked.

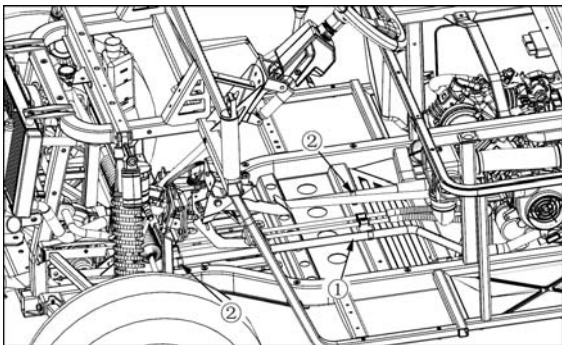

① Radiator hose    ② Clamp bands

## ◆ Precaution on Overheating

Take the following actions in the event the coolant temperature gauge is showing red bars.

1. Stop the vehicle operation in a safe place and keep the engine unloaded idling.
2. Don't stop the engine suddenly, but stop it after about 5 minutes of idling.
3. Do not open radiator cap until engine has sufficiently cooled down.
4. Inspect radiator for debris in screen / clogged radiator fins, coolant level in radiator and proper coolant fan operation. Correct any of these findings and restart engine. Allow it to get to normal operation temperature to ensure issue has been corrected.

## ■ Checking Intake Air Tube

1. Check to see if the hoses and hose clamps are tight and not damaged.

If hoses and clamps are found to be worn or damaged, replace or repair them at once.

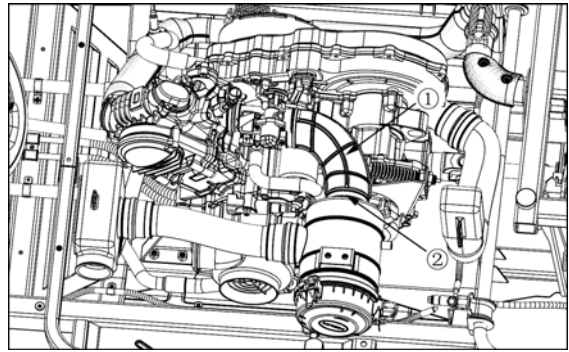

① Hose    ② Hose joint

## EVERY 300 HOURS

### ■ Checking Tire

1. Check to see if tires are not damaged.
2. If the tires are cracked, bulged, or cut, or they are worn out, replace or repair them at once.

### ◆ Tire Tread Depth

Always replace the tires when the tread depth is worn to minimum allowable.

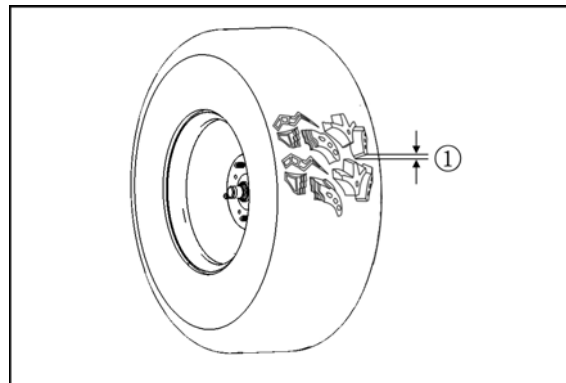

① 3mm(0.12in)

# Periodic Service

## EVERY 400 HOURS

### ■ Changing Transmission Fluid



### CAUTION

To avoid personal injury:

- Park the vehicle on a flat surface, raise the cargo bed, mount the safety support.
  - Allow engine to cool down sufficiently, oil can be hot and can burn.
1. Park the vehicle on a flat surface, raise the cargo bed, mount the safety support.
  2. To drain the used oil, remove the drain plug at the bottom of the transmission case and drain the oil completely into the oil pan.
  3. After draining, reinstall the drain plug.
  4. After running the engine for a few minutes, stop the engine and check the oil level again; add oil to prescribed level.

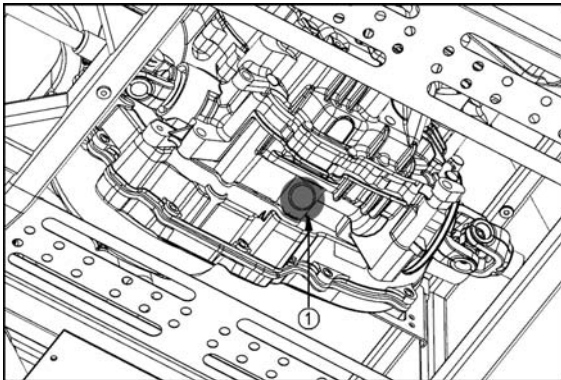

① Drain plug

### IMPORTANT:

- Do not operate the vehicle immediately after changing the transmission fluid.
- Run the engine at medium speed for a few minutes to prevent damage to the transmission.

### ■ Changing Front and Rear Axle Case Oil

1. Park the vehicle on a firm, flat and level surface.
2. To drain the used oil, remove the drain the oil completely into the oil pan.
3. Fill with the new oil up to the upper notch on the dipstick.

Oil capacity for front axle case	0.28L (0.072U.S.gals.)
Oil capacity for rear axle case	0.20L (0.052U.S.gals.)

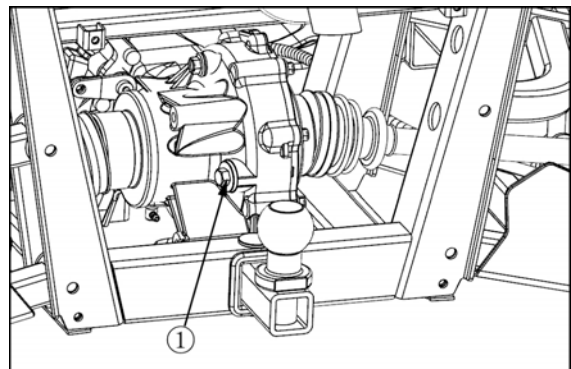
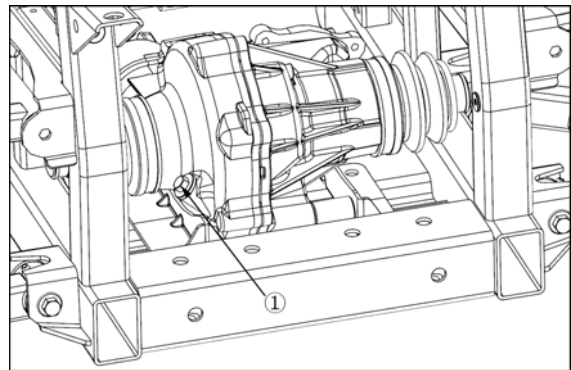

- ① Front axle case drain plug
- ② Rear axle case drain plug

## EVERY 500 HOURS

### ■ Replacing Fuel Filter

Consult your local dealer for this service.

# Periodic Service

## EVERY 1500 HOURS

### ■ Checking Injection and Fuel Pump

Consult your local dealer for this service.

## EVERY 1 YEAR

### ■ Refer to Service Interval Chart on page 9-2

## EVERY 2 YEARS

### ■ Refer to Service Interval Chart on page 9-2

### ■ Flushing Cooling System and Changing Coolant



## CAUTION

To avoid personal injury:

- Do not remove the radiator cap while coolant is hot. When cool, slowly rotate cap to the first stop and allow sufficient time for excess pressure to escape before removing the cap completely.

1. Stop the engine and let cool down.
2. To drain the coolant, open the radiator drain plug and remove radiator cap. The radiator cap must be removed to completely drain the coolant.
3. After all coolant is drained, close the drain plug.
4. Fill with clean water and cooling system cleaner.

5. Follow directions of the cleaner instruction.
6. After flushing, fill with clean water and anti-freeze until the coolant level is just below the radiator cap.  
Fill with fresh water up to the "FULL" mark on the recovery tank.
7. Start and operate the engine for few minutes.
8. Stop the engine and let cool.
9. Check coolant level of recovery tank and coolant if necessary.

Coolant capacity	1.8L (1.89 U.S.qts.)
------------------	----------------------

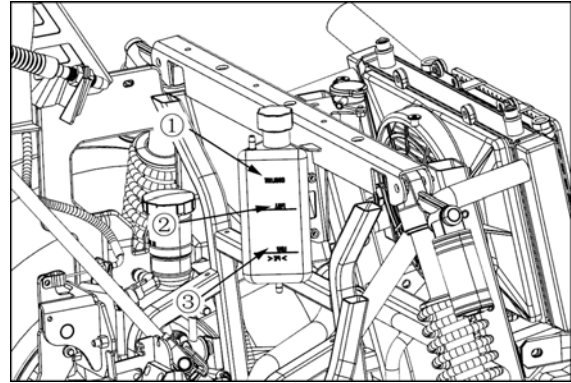

- ① Recovery tank    ② "FULL"  
③ "LOW"

### IMPORTANT:

- Do not start engine without coolant.
- Use clean, fresh water and anti-freeze to fill the radiator and recovery tank.
- When the anti-freeze is mixed with water, the antifreeze mixing ratio must be less than 50%.
- Securely tighten radiator cap. If the cap is loose or improperly fitted, water may leak out and the engine could overheat.



# Periodic Service

## ■ Anti-Freeze



### CAUTION

#### To avoid personal injury:

- When using antifreeze, put on some protection such as rubber gloves.(Antifreeze contains poison.)
- If you should drink antifreeze, throw up at once and take medical attention.
- When antifreeze comes in contact with the skin or clothing, wash it off immediately.。
- Do not mix different types of Antifreeze.

The mixture can produce chemical reaction causing harmful substances.

- Antifreeze is extremely flammable and explosive under certain conditions. Keep fire and children away from antifreeze.
- When draining fluids from the engine, place some container underneath the engine body.
- Do not pour waste onto the grounds, down a drain, or into any water source.
- Also, observe the relevant environmental protection regulations when disposing of antifreeze.

If it freezes, coolant can damage the cylinders and radiator. If the ambient temperature falls below 0°C(32°F) or before a long-term storage, let out cooling water completely, or mix fresh water with long-life coolant and fill the radiator and recovery tank with the mixture.

1. Long-life coolant (hereafter LLC) comes in several types. Use ethylene glycol(EG) type for this engine.
2. Before employing LLC-mixed cooling water, fill the radiator with fresh water and empty it again.

Repeat this procedure 2 or 3 times to clean up the inside.

3. Mixing the LLC
4. The procedure for the mixing of water and antifreeze differs according to the make of the antifreeze and the ambient temperature. Refer to SEA J1034 standard, more specifically also to SAE J814c.

#### IMPORTANT:

- When the antifreeze is mixed with water, the antifreeze mixing ratio must be less than 50%.

VOL%	Freezing point		Boiling point	
	°C	°F	°C	°F
40	-24	-12	106	222
50	-37	-34	108	226

\*At 1.013x10<sup>5</sup>Pa (760mmHg) pressure (atmospheric).

A higher boiling point is obtained by using a radiator

pressure cap which permits the development of pressure within the cooling system.

5. Adding the LLC
    - 1) Add only water if the mixture reduces in amount by evaporation.
    - 2) If there is a mixture leak, add the LLC of the same manufacturer and type in the same mixture percentage.
- \* Never add any long-life coolant of different manufacturer.(Different brands may have different additive components, and the engine may fail to perform as specified.)
6. When the LLC is mixed, do not employ any radiator cleaning agent. The LLC contains

# Periodic Service

anticorrosive agent. If mixed with the cleaning agent, sludge may build up, adversely affecting the engine parts.

7. The vehicle's genuine long-life coolant has a service life of 2 years. Be sure to change the coolant every 2 years.

## NOTE:

- The above data represent industry standards that necessitate a minimum glycol content in the concentrated antifreeze.
- When the coolant level drops due to evaporation, add water only to keep the antifreeze mixing ratio less than 50%. In case of leakage, add antifreeze and water in the specified mixing ratio before filling into the radiator.

## ■ Replacing Radiator Hose (Water pipes)

Replace the hoses and clamps.

(See "Checking Radiator Hose and Clamp" in "EVERY 200 HOURS" in "PERIODIC SERVICE" section.)

## ■ Replacing Fuel Hose

Consult your local HUANSONG Dealer for this service.

## ■ Replacing Brake Master Cylinder (Inner parts)

Consult your local dealer for this service.

## ■ Replacing Front Brake Seal

Consult your local dealer for this service.

## ■ Replacing Rear Brake Cylinder Seal

Consult your local dealer for this service.

## ■ Replacing Intake Air Line

Consult your local dealer for this service.

## EVERY 4 YEARS

## ■ Replacing Brake Hose

Consult your local Dealer for this service.

## ■ Replacing Slow-Blow Fuses

The slow-blow fuses are intended to protect the electrical cabling. If any of them have blown out, be sure to pinpoint the cause.

## ◆ Replacing procedure

- 1) Disconnect the negative cable of the battery.
- 2) Open the slow-blow fuse box cover.
- 3) Pull out the slow-blow fuse.
- 4) Insert a new slow-blow fuse into the box.
- 5) Close the slow-blow fuse box cover.
- 6) Connect the negative battery cable.

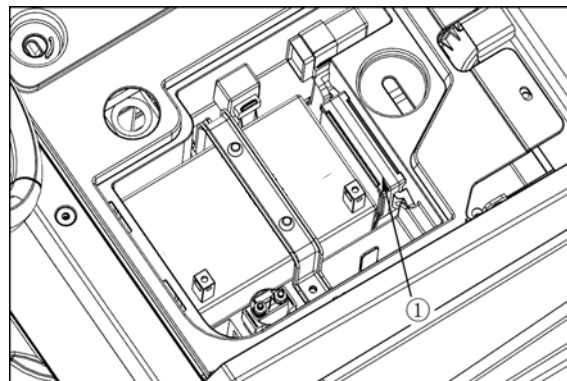

① Slow-blow fuse box cover

# Periodic Service

## ■ Replacing Light Bulb

- Head lights  
Take the bulb out of the light body and replace it with a new one.
- Other lights  
Detach the lens and replace the bulb

Light	Capacity
Head lights	2x55W
Tail light	LED 0.5W
Brake light	LED 1W
Instrument panel light	1W

## STORAGE



### CAUTION

To avoid personal injury:

- Do not clean the vehicle when the engine is running.
- To avoid the danger of exhaust fume poisoning, do not operate the engine in a closed building without proper ventilation.
- When storing, remove the key from the key switch to avoid unauthorized persons from operating the vehicle and getting injured.

## VEHICLE STORAGE

If you intend to store your vehicle for an extended period of time, follow the procedures outlined below.

These procedures will insure that the vehicle is ready to operate with minimum preparation when it is removed from storage.

1. Check the bolts and nuts for looseness, and

tighten if necessary.

2. Apply grease to vehicle areas where bare metal will rust also to pivot areas.
3. Unload from cargo bed.
4. Inflate the tire to a pressure a little higher than usual.
5. Charge the engine oil and run the engine to circulate oil throughout the engine block and internal moving parts for about 5 minutes.
6. With all implements lowered to the ground, coat any exposed rods with grease (if equipped).
7. Remove the battery from the vehicle. Store the battery following the battery storage procedures.
8. Keep the vehicle in a dry place where the vehicle is sheltered from the elements. Cover the vehicle.
9. Keep the vehicle indoors in a dry area that is protected from sunlight and excessive heat. If the vehicle must be stored outdoors, cover it with a waterproof tarpaulin. Put boards under the tires to keep dampness away from tire. Keep the tires out of direct sunlight and extreme heat.

### IMPORTANT:

- When washing the vehicle, be sure to stop the engine. Allow sufficient time for the engine to cool before washing.
- Do not wash with a high-pressure car-washing machine.
- Cover the vehicle after the muffler and the engine have cooled down.

## Periodic Service

### REMOVING THE VEHICLE FROM STORAGE

1. Check the tire air pressure and inflate the tires if they are low.
2. Install battery before installing the battery, Be sure it is fully charged.
3. Check to see if the fan works.
4. Check all fluid levels (engine oil, transmission oil, engine coolant, transmission coolant and any attached implements).
5. Start the engine. Observe all gauges. If all gauges are functioning properly and reading normal, move the vehicle outside. Once outside, park the vehicle and let the engine idle for at least five minutes. Shut the engine off and work around vehicle and make a visual inspection looking for evidence of oil or water leaks.
6. With the engine fully warm up. Release the parking brake and test the brakes for proper adjustment as you move forward. Adjust the brake as necessary.

# Troubleshooting

## ENGINE TROUBLESHOOTING

If something is wrong with the engine, refer to the table below for the cause and its corrective countermeasure.

Trouble	Cause	Countermeasure
Engine is difficult to start or cannot start.	<ul style="list-style-type: none"> <li>No fuel flow</li> </ul>	<ul style="list-style-type: none"> <li>Check the fuel tank and fuel filter.</li> <li>Check the electric fuel pump.</li> <li>Check the injector.</li> <li>Check the ECU with Motor Scan KF90121.</li> <li>Replace filter electric fuel pump injector and ECU If necessary.</li> </ul>
	<ul style="list-style-type: none"> <li>Water is in the fuel system</li> </ul>	<ul style="list-style-type: none"> <li>Check to see if the fuel tank cover is tight.</li> </ul>
	<ul style="list-style-type: none"> <li>In winter, oil viscosity increases, and Engine revolution is slow.</li> </ul>	<ul style="list-style-type: none"> <li>Use oils of different viscosities, depending on ambient temperatures.</li> </ul>
	<ul style="list-style-type: none"> <li>Battery becomes weak and the engine does not turn over quick enough.</li> </ul>	<ul style="list-style-type: none"> <li>Clean battery cables and terminals.</li> <li>Charge the battery.</li> <li>In cold weather (-15°C), always remove the battery from the vehicle, charge and store it indoors. install it on the vehicle only when the vehicle is going to be used.</li> </ul>
Engine power is insufficient	<ul style="list-style-type: none"> <li>Insufficient fuel.</li> <li>The injector is clogged.</li> <li>Crankshaft position sensor is bad..</li> <li>The air cleaner is clogged.</li> <li>Spark plug is dirty or fouled.</li> <li>Ignition coil is bad.</li> </ul>	<ul style="list-style-type: none"> <li>Check the fuel system.</li> <li>Clean or replace the injector.</li> <li>Replace crankshaft position sensor.</li> <li>Clean or replace the air cleaner.</li> <li>Clean or replace the spark plug.</li> <li>Replace the ignition coil.</li> </ul>
Engine stops suddenly	<ul style="list-style-type: none"> <li>Check with the diagnostic instrument (Motor Scan KF90121 ).</li> </ul>	
Engine overheats	<ul style="list-style-type: none"> <li>Engine overloaded</li> </ul>	<ul style="list-style-type: none"> <li>Shift to lower gear or reduce load.</li> </ul>
	<ul style="list-style-type: none"> <li>Low coolant level.</li> </ul>	<ul style="list-style-type: none"> <li>Fill cooling system to the correct level;</li> <li>Check radiator and hoses for loose connections or leaks.</li> </ul>
	<ul style="list-style-type: none"> <li>The motor driven fan does not turn.</li> </ul>	<ul style="list-style-type: none"> <li>Check to see if the fuse is not blown.</li> <li>Check the electric system.</li> </ul>
	<ul style="list-style-type: none"> <li>Dirty radiator core or grille screens.</li> </ul>	<ul style="list-style-type: none"> <li>Remove all trash.</li> </ul>
	<ul style="list-style-type: none"> <li>Coolant flow route corroded.</li> </ul>	<ul style="list-style-type: none"> <li>Flush cooling system.</li> </ul>

If you have any questions, consult your local dealer.

# Troubleshooting

## Diagnostic Trouble Code Table

MT05 ECU Malf Code	
Table:23	
Malf code in MT05	Description
<b>P0107</b>	MAP Circuit Low Voltage or Open
<b>P0108</b>	MAP Circuit High Voltage
<b>P0112</b>	IAT Circuit Low Voltage
<b>P0113</b>	IAT Circuit High Voltage or Open
<b>P0117</b>	Coolant/Oil Temperature Sensor Circuit Low Voltage
<b>P0118</b>	Coolant/Oil Temperature Sensor Circuit High Voltage or Open
<b>P0122</b>	TPS Circuit Low Voltage or Open
<b>P0123</b>	TPS Circuit High Voltage
<b>P0131</b>	O2A Circuit Low Voltage
<b>P0132</b>	O2A Circuit High Voltage
<b>P0031</b>	O2A Heater Circuit High Voltage
<b>P0032</b>	O2A Heater Circuit Low Voltage
<b>P0201</b>	Injector 1 Circuit Malfunction
<b>P0202</b>	Injector 2 Circuit Malfunction
<b>P0230</b>	FPR Coil Circuit Low Voltage or Open
<b>P0232</b>	FPR Coil Circuit High Voltage
<b>P0336</b>	CKP Sensor Noisy Signal
<b>P0337</b>	CKP Sensor No Signal
<b>P0351</b>	Cylinder 1 Ignition Coil Malfunction
<b>P0352</b>	Cylinder 2 Ignition Coil Malfunction
<b>P0505</b>	Idle Speed Control Error
<b>P0562</b>	System Voltage Low
<b>P0563</b>	System Voltage High
<b>P0650</b>	MIL Circuit Malfunction
<b>P1693</b>	Tachometer Circuit Low Voltage
<b>P1694</b>	Tachometer Circuit High Voltage

If you have any questions, consult your local dealer.

# Troubleshooting

## BATTERY TROUBLESHOOTING

Trouble	Cause	Countermeasure	Preventive measure
Starter does not function	<ul style="list-style-type: none"> <li>Battery overused until lights are dim.</li> </ul>	<ul style="list-style-type: none"> <li>Charge the battery sufficiently.</li> </ul>	<ul style="list-style-type: none"> <li>Charge the battery properly.</li> </ul>
	<ul style="list-style-type: none"> <li>Battery has not been recharged.</li> </ul>		
	<ul style="list-style-type: none"> <li>Poor terminal connection</li> </ul>	<ul style="list-style-type: none"> <li>Clean the terminal and tighten securely.</li> </ul>	<ul style="list-style-type: none"> <li>Keep the terminal clean and tight. Apply grease and treat with anti-corrosive.</li> </ul>
	<ul style="list-style-type: none"> <li>Battery life expired</li> </ul>	<ul style="list-style-type: none"> <li>Replace new battery</li> </ul>	
From beginning starter does not function, and lights soon become dim	<ul style="list-style-type: none"> <li>Insufficient charging</li> </ul>	<ul style="list-style-type: none"> <li>Charge battery Insufficiently</li> </ul>	<ul style="list-style-type: none"> <li>Battery must be serviced properly before initial use</li> </ul>
When viewed from the top of plates, look whitish. * Refillable type battery only	<ul style="list-style-type: none"> <li>Battery was used with an insufficient amount of electrolyte.</li> </ul>	<ul style="list-style-type: none"> <li>Add distilled water and charge the battery.</li> </ul>	<ul style="list-style-type: none"> <li>Regularly check the electrolyte level.</li> </ul>
	<ul style="list-style-type: none"> <li>Battery was used with too much without recharging.</li> </ul>	<ul style="list-style-type: none"> <li>Charge battery Insufficiently</li> </ul>	<ul style="list-style-type: none"> <li>Charge battery properly</li> </ul>
Recharging is impossible.	<ul style="list-style-type: none"> <li>Battery life expired.</li> </ul>	<ul style="list-style-type: none"> <li>Replace battery.</li> </ul>	
Terminals are severely corroded and heat up.	<ul style="list-style-type: none"> <li>Poor terminal connection</li> </ul>	<ul style="list-style-type: none"> <li>Clean the terminal and tighten securely.</li> </ul>	<ul style="list-style-type: none"> <li>Keep the terminal clean and tight. Apply grease and treat with anti-corrosives.</li> </ul>
Battery electrolyte level drops rapidly. * Refillable type battery only	<ul style="list-style-type: none"> <li>There is a crack or pin holes in the electrolytic cells.</li> </ul>	<ul style="list-style-type: none"> <li>Replace battery.</li> </ul>	
	<ul style="list-style-type: none"> <li>Charging system trouble.</li> </ul>	<ul style="list-style-type: none"> <li>Consult your local dealer.</li> </ul>	

- If you have any questions, consult your local dealer.
- The factory installed battery is non-refillable type.

# Troubleshooting

## MACHINE TROUBLESHOOTING

Trouble	Cause	Countermeasure
Gear Shifter not Operational	<ul style="list-style-type: none"> <li>● High idling speed of engine</li> </ul>	<ul style="list-style-type: none"> <li>● Replace throttle cable;</li> <li>● Replace throttle pedal</li> <li>● Replace the throttle</li> </ul>
	<ul style="list-style-type: none"> <li>● High rotary speed for clutch connection.</li> </ul>	<ul style="list-style-type: none"> <li>● Replace the junior clutch spring;</li> <li>● Replace the primary clutch.</li> </ul>
	<ul style="list-style-type: none"> <li>● Gear shift cable out of adjustment</li> </ul>	<ul style="list-style-type: none"> <li>● Put the gearshift rod into the position of "N".</li> <li>● Put the gearshift arm of engine into "N".</li> <li>● Adjust the cable and the bolt.</li> <li>● Lock tightly.</li> </ul>
	<ul style="list-style-type: none"> <li>● Gear abrasion</li> </ul>	<ul style="list-style-type: none"> <li>● Replace the gears</li> </ul>
Transmission noise	<ul style="list-style-type: none"> <li>● Tolerance between inner &amp; outer gears out of tolerance.</li> </ul>	<ul style="list-style-type: none"> <li>● Replace the gears</li> </ul>
Low vehicle speed or power	<ul style="list-style-type: none"> <li>● Parking brake engaged</li> </ul>	<ul style="list-style-type: none"> <li>● Adjust cable</li> </ul>
	<ul style="list-style-type: none"> <li>● CVT belt slipping</li> </ul>	<ul style="list-style-type: none"> <li>● Replace CVT transmission belt</li> <li>● Replace the clutch.</li> </ul>
Soft / No Brakes	<ul style="list-style-type: none"> <li>● Low brake fluid</li> </ul>	<ul style="list-style-type: none"> <li>● Check the brake fluid level</li> </ul>
	<ul style="list-style-type: none"> <li>● Air in brake lines</li> </ul>	<ul style="list-style-type: none"> <li>● Contact Dealer.</li> </ul>
	<ul style="list-style-type: none"> <li>● Brake discs worn</li> </ul>	<ul style="list-style-type: none"> <li>● Contact Dealer.</li> </ul>
	<ul style="list-style-type: none"> <li>● Caliper bolt loose</li> </ul>	<ul style="list-style-type: none"> <li>● Secure bolt</li> </ul>

If you have any questions, consult your local dealer.



# ACCESORIES

Consult your local dealer for additional accessories to add to your vehicle:

1. Heavy Duty Front and Rear Bumpers
2. Front Basket
3. Hard Cab Enclosure
4. Soft Cab Enclosure
5. Snow Plow
6. LED Lights
7. Spare Tire Carrier

# Hisun Motors Corp., U.S.A. Emission Control System Warranty Statement

## YOUR WARRANTY RIGHTS AND OBLIGATIONS

---

The U.S. Environmental Protection Agency and **Hisun Motors Corp., U.S.A.** (hereinafter "**HISUN**") are pleased to explain the emission control system warranty on your Off-Road vehicle. New off-road motor vehicles must be designed, built and equipped to meet U.S. EPA Federal and California anti-smog standards. HISUN must warrant the emission control system on your vehicle for 5,000 km, or at least 30 months, whichever comes first, provided that there has been no abuse, neglect or improper maintenance of your vehicle. This off-road vehicle was designed to meet the emission standards for 10,000 km, or five years, whichever comes first.

Your emission control system warranty covers components whose failure would increase an engine's emissions of any regulated pollutant

Where a warrantable condition exists, HISUN will repair your vehicle at no cost to you, including diagnosis, parts and labor.

If an emission-related part on your vehicle is defective, the part will be repaired or replaced by HISUN. This is your EMISSION CONTROL SYSTEM WARRANTY.

**NOTICE!** Use of this vehicle in any type of competitive event completely and absolutely voids this and all other warranties offered by HISUN.

## OWNER'S WARRANTY RESPONSIBILITIES

As the vehicle owner, you are responsible for the performance of the required maintenance listed in your owner's manual. HISUN recommends that you retain all receipts covering maintenance on your vehicle, but HISUN cannot deny warranty solely for the lack of receipts or for your failure to ensure the performance of all scheduled maintenance.

You are responsible for presenting your vehicle to the HISUN dealer as soon as a problem exists. The warranty repairs should be completed in a reasonable amount of time, not to exceed 30 days.

As the vehicle owner, you should be aware that HISUN may deny your warranty coverage if your vehicle or a part has failed due to abuse, neglect, improper maintenance or unapproved modifications.

If you use your vehicle in any type of competitive event, this warranty is immediately and completely void.

If you have any questions regarding your warranty rights and responsibilities, you should contact Hisun Motors Corp., U.S.A., 310 E, University Drive, McKinney, TX 75069 (Phone: 972-446-0760 or Toll Free: 877-838-6188), or the U.S. Environmental Protection Agency at 2000 Traverwood Drive, Ann Arbor, MI 48105.



## Hisun Motors Corp., U.S.A. Limited Warranty on Emission Control System

### YOUR WARRANTY RIGHTS AND OBLIGATIONS

---

Hisun Motors Corp., U.S.A. warrants that each new off-road vehicle:

- A. is designed, built and equipped so as to conform at the time of initial retail purchase with all applicable regulations of the United States Environmental Protection Agency, and
- B. is free from defects in material and workmanship which cause such vehicle to fail to conform to applicable regulations of the United States Environmental Protection Agency for the periods specified above.
- I. **Coverage.** Warranty defects shall be remedied during customary business hours at any authorized HISUN dealer located within the United States of America in compliance with the Clean Air Act and applicable regulations of the United States Environmental Protection Agency. Any part or parts replaced under this warranty shall become the property of HISUN.

II. **Limitations** This Emission Control System Warranty shall not cover any of the following:

- A. Repair or replacement as a result of
- (1) accident,
  - (2) misuse,
  - (3) repairs improperly performed or replacements improperly installed, unless performed by a HISUN authorized dealer,
  - (4) use of improper replacement parts or accessories not conforming to specifications set forth by HISUN, which adversely affect performance and/or
  - (5) Use in competitive racing or related events.
- B. Inspections, replacement of parts and other services and adjustments required for required maintenance.
- C. Any vehicle equipped with an odometer or hour meter on which the odometer mileage or hour meter reading has been changed so that actual mileage cannot be readily determined.

### III. Limited Liability

- A. The liability of HISUN under this Emission Control System Warranty is limited solely to the remedying of defects in material or workmanship by an authorized HISUN dealer at its place of business during customary business hours. This warranty does not cover inconvenience or loss of use of the vehicle or transportation of the vehicle to or from the HISUN dealer. HISUN shall not be liable for any other expenses, loss or damage, whether direct, incidental, consequential or exemplary arising in connection with the sale or use of or inability to use the vehicle for any purpose. Some states do not allow the exclusion or limitation of any incidental or consequential damages, so the above limitations may not apply to you.



## Hisun Motors Corp., U.S.A. Limited Warranty on Emission Control System

**B.** No express emission control system warranty is given by HISUN except as specifically set forth herein. Any emission control system warranty implied by law, including any warranty of merchantability or fitness for a particular purpose, is limited to the express emission control system warranty terms stated in this warranty. The foregoing statements of warranty are exclusive and in lieu of all other remedies. Some states do not allow limitations on how long an implied warranty lasts, so the above limitations may not apply to you.

**C.** No dealer is authorized to modify this Limited Emission Control System Warranty issued by HISUN.

**IV. LEGAL RIGHTS.** This warranty gives you specific legal rights, and you may also have other rights which vary from state to state.

**V.** This warranty is in addition to the limited vehicle warranty.

**VI. ADDITIONAL INFORMATION.** Any replacement part that is equivalent in performance and durability may be used in the performance of any maintenance or repairs by the owner. However, HISUN is not liable for these parts. The owner is responsible for the performance of all required maintenance. Such maintenance may be performed at a service establishment or by any individual. The warranty period begins when the vehicle is placed into service.

If you have any questions regarding your warranty rights and responsibilities, you should contact Hisun Motors Corp., U.S.A., or the U.S. Environmental Protection Agency at 2000 Traverwood Drive, Ann Arbor, MI 48105.

**Hisun Motors Corp., U.S.A.**

310 E. University Drive

McKinney, TX 75069

Phone: 972-446-0760

Fax: 972-446-0765

Toll-Free: 877-838-6188



# AXIS

OFF-ROAD



## AXIS OFF-ROAD

310 E. UNIVERSITY DR.

McKINNEY, TX 75069



@AXISOFFROAD

FOR QUESTIONS REGARDING YOUR  
PRODUCT, PLEASE CONTACT US AT:  
(972) 446-0760 OR [WWW.AXIS-OFFROAD.COM](http://WWW.AXIS-OFFROAD.COM)

COPYRIGHT © AXIS OFF-ROAD. ALL INFORMATION CONTAINED WITHIN THIS PUBLICATION IS BASED UPON THE LATEST PRODUCT SPECIFICATIONS AND INFORMATION AT THE TIME OF PUBLICATION. BECAUSE OF THE CONSTANT ENHANCEMENT IN THE QUALITY AND DESIGN OF PRODUCTION COMPONENTS, MINOR DISCREPANCIES MAY VARY BETWEEN THE ACTUAL VEHICLE AND THE INFORMATION PRESENTED IN THIS PUBLICATION. NO LIABILITY CAN BE ACCEPTED FOR OMISSIONS OR INACCURACIES. ANY REPRINTING OR REPRODUCTION, WHETHER WHOLE OR IN PART OF THIS PUBLICATION IS STRICTLY PROHIBITED.